



RGA

AIR COOLED WATER CHILLERS AND HEAT PUMPS
WITH AXIAL FANS

53.5 ÷ 200 kW IN COOLING MODE

57.5 ÷ 214 kW IN HEATING MODE



TECHNICAL MANUAL

The manufacturer declines all responsibility for any inaccuracies in this manual due to printing or typing errors.
The reserves the right to modify the products contents in this catalogue without previous notice.

TABLE OF CONTENTS

THIS MANUAL IS DIVIDED INTO SECTIONS. THEIR NAMES APPEAR IN THE HEADING OF EACH PAGE.

GENERAL SPECIFICATIONS	5	CORRECTION FACTOR FOR THE USE OF GLYCOL	42
PRESENTATION OF THE UNIT	5	CORRECTION FACTOR FOR THE USE OF GLYCOL IN HEATING MODE ..	42
IDENTIFICATION CODE OF THE UNIT	5	CORRECTION FACTOR FOR THE USE OF GLYCOL IN COOLING MODE ..	42
DESCRIPTION OF THE COMPONENTS	6	GENERAL SPECIFICATIONS - BRINE UNIT BR - BP	43
HYDRAULIC AND COOLING CIRCUIT COMPONENTS	8	SPECIFIC DATA FOT BRINE UNIT (BR-BP)	43
DESUPERHEATER UNIT VD	9	NOISE LEVELS	44
TOTAL HEAT RECOVERY UNIT VR	10	AB STANDARD UNIT	44
ACCESSORIES AND OPTIONAL EQUIPMENT	11	AS LOW NOISE UNIT	44
ACCESSORIES	11	AX EXTRA LOW NOISE UNIT	44
MECHANICAL OPTIONS	14	OPERATING RANGE	45
ELECTRICAL OPTIONS	14	OPERATING RANGE	45
TECHNICAL SPECIFICATIONS AND STANDARD PERFORMANCES		WATER PRESSURE DROP PLATE HEAT EXCHANGER	46
- IR COOLING UNIT ONLY	15	WATER PRESSURE DROP OF THE DESUPERHEATER VD	47
TECHNICAL SPECIFICATIONS OF UNIT AB STANDARD UNIT	15	WATER PRESSURE DROP TOTAL HEAT RECOVERY VR	47
STANDARD PERFORMANCES AB STANDARD UNIT	16	WORKING HEAD OF THE HYDRONIC KIT	
TECHNICAL SPECIFICATIONS OF UNIT AS LOW NOISE UNIT	18	MP AM STD,MP SS STD AND MPM AM STD	49
STANDARD PERFORMANCES AS LOW NOISE UNIT	19	WORKING HEAD OF THE HYDRONIC KIT	
TECHNICAL SPECIFICATIONS OF UNIT		MP AM HP1,MP SS HP1 AND MPM AM HP1	50
AX EXTRA LOW NOISE VERSION	21	MAXIMUM VOLUME OF WATER	51
STANDARD PERFORMANCES AX EXTRA LOW NOISE VERSION ..	22	MAXIMUM WATER VOLUME OF THE SYSTEM WITH HYDRONIC KIT ..	51
DESUPERHEATER UNIT (VD)	24	DIMENSIONAL DATA	51
RECOVERED HEATING CAPACITY DESUPERHEATER UNIT (VD) ..	25	OVERALL DIMENSIONS	51
TOTALE HEAT RECOVERY UNIT (VR)	26	DESCRIPTION OF THE COMPONENTS	52
RECOVERED HEATING CAPACITY TOTAL HEAT RECOVERY UNIT (VD)	27	MINIMUM SPACE REQUIRED FOR OPERATION	52
		POSITION OF CONDENSATE DRAIN	52
TECHNICAL SPECIFICATIONS AND STANDARD PERFORMANCES		WEIGHT DURING OPERATION AND TRANSPORT	54
- IP HEAT PUMP UNITS	28		
TECHNICAL SPECIFICATIONS OF UNIT AB STANDARD UNIT	28		
STANDARD PERFORMANCES IN COOLING MODE			
AB STANDARD UNIT	29		
STANDARD PERFORMANCES IN HEATING MODE			
AB STANDARD UNIT	31		
TECHNICAL SPECIFICATIONS OF UNIT AS LOW NOISE UNIT	32		
STANDARD PERFORMANCES IN COOLING MODE			
AS LOW NOISE UNIT	33		
STANDARD PERFORMANCES IN HEATING MODE			
AS LOW NOISE UNIT	35		
TECHNICAL SPECIFICATIONS OF UNIT			
AX EXTRA LOW NOISE VERSION	36		
STANDARD PERFORMANCES IN COOLING MODE			
AX EXTRA LOW NOISE VERSION	37		
STANDARD PERFORMANCES IN HEATING MODE			
AX EXTRA LOW NOISE VERSION	39		
DESUPERHEATER UNIT (VD)	40		
RECOVERED HEATING CAPACITY DESUPERHEATER UNIT (VD) ..	41		

GENERAL SPECIFICATIONS

Unit description

This new series of industrial chillers and heat pumps has been designed to meet the demands of global markets in the small-medium power industrial and commercial plants. Units are compact and highly configurable, built to fit different types of plants so to meet the needs of highly qualified engineers.

Units are water chillers and heat pumps condensed in air with axial fans suitable for outdoor installation: the structure and panels are robust, made of galvanized and painted steel; all fasteners are made of stainless steel or galvanized steel, the frame containing the electrical equipment and all the components exposed to weather have a minimum **IP54** degree of protection.

This series is composed of twelve models divided in four sizes with nominal cooling capacity from **53.5 to 200 kW** and thermal capacity from **57.5 to 214 kW**.

The units product cold water from 5 to 25°C (in summer) and hot water from 30 to 55°C (in winter) and **as standard** they are equipped with continuous adjustment of axial fans rotating speed in order to allow the units to operate both with low outdoor temperature in cooling mode and with high outdoor temperature in heating mode as well as to reduce noise emissions.

All the units are equipped with 2 scroll compressors arranged in pairs (tandem) on 1 circuit operating with **environmental friendly R410A gas**, brazed plate heat exchanger completely insulated and protected by water side with a differential pressure control and with an antifreeze electrical heater, coil heat exchanger made of louver aluminum fins and copper tubes, axial fans with profiled blades to contain noise and with thermal protection built-in, on-board electrical control panel equipped with control system to manage the main functions.

Hydronic group (MP) composed of fittings and connections is available as an accessory with 1 or 2 pumps and also with high available head pumps or with **Inverter** modulating pump; the accessory Water Storage Tank (SAA) is completely insulated and available on delivery side or for primary-secondary hydraulic circuit (Victaulic connections already in place) depending on the kind of plants to serve.

A variety of other accessories are available to extend the capabilities of the units.

During the design of the units particular attention has been given to achieve high system efficiency, to reduce overall energy consumptions and sound levels in order to meet the increasingly restrictive laws in terms of noise. Upon request, you can choose for a Standard Unit (AB) or Low noise unit (AS) which provides sound attenuation thanks to sound absorbing insulation in compressors area, sound jackets on compressors and reduced speed axial fans, or a Extra low noise unit (AX), which provides in addition slower axial fans and more powerful finned coils.

All units are accurately build in compliance with the existing standards and are individually tested in factory. Only electrical and hydraulic connections are required for installation.

Identification code of the unit

The codes that identify the units are listed below and include the sequences of letters that determine the meanings for the various versions and set-ups.

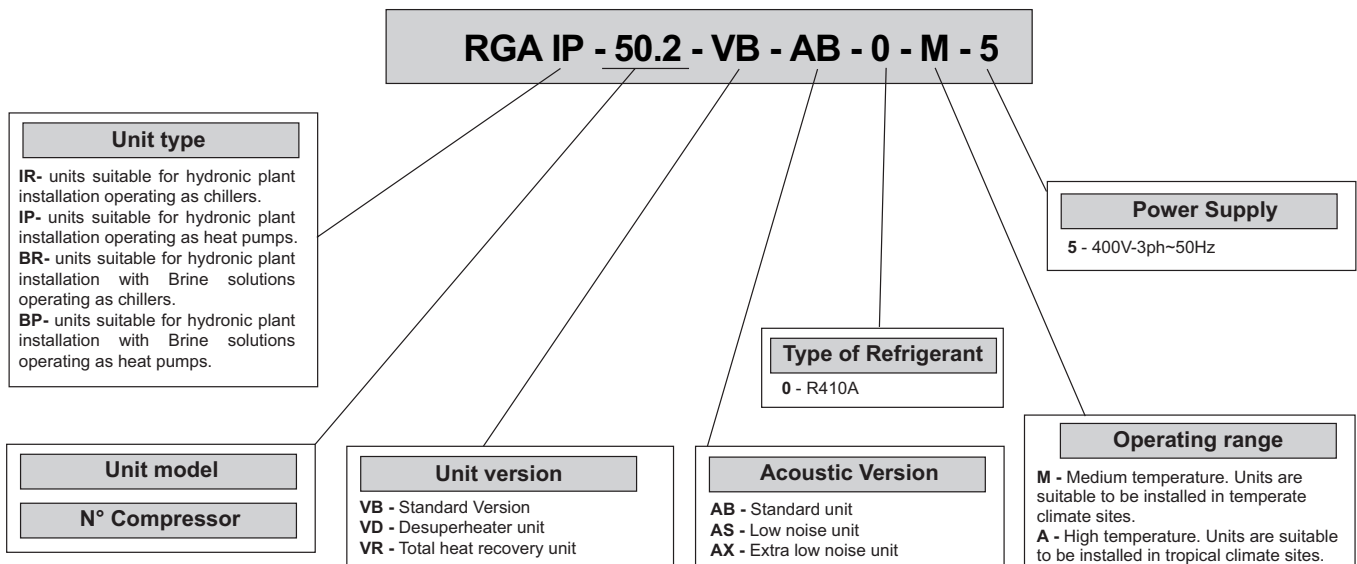

The available special versions are described below:

VB: **Standard unit.**

VD: **Desuperheater unit (available for both IR units and IP units)**

Produces cold water in the same way as the standard version plus hot water **from 30 to 70°C** at the same time. This is achieved by installing a water-refrigerant gas heat exchanger between the compressor and coils in order to recover 15 to 20% of the heating capacity that would otherwise be dispersed in the air.

VR: **Total Heat Recovery unit**

Produces cold water as in the standard version plus hot water at a temperature of **35 to 50°C** at the same time. This is achieved thanks to a water-refrigerant gas heat exchanger that totally recovers the heating capacity that would otherwise be dispersed in the air. The total heat recovery function is enabled and disabled by means of a valve on the compressor delivery of each circuit: when the temperature of the water that enters the recuperator drops, the valve switches the hot gas flow from the condensing coils to the recovery heat exchanger. On the other hand, when the temperature of the water reaches the set-point, the valve shuts off the heat recuperator and switches the hot gas flow to the condensing coils.

GENERAL SPECIFICATIONS

Description of the components

The complete series of industrial chillers and heat pumps for use in hydronic systems includes **12 constructional sizes** ranging from **53.5 to 200 kW** in the cooling mode and **from 57.5 to 214 kW** in the heating mode.

Main components:

1. Fans. These are the helical type with scythe-shaped blades to increase the efficiency and reduce the noise level. The fans are directly coupled to the single-phase motor by means of an external rotor. Thermal protection against operating faults is installed inside the winding. As standard they are equipped with continuous adjustment of axial fans rotating speed in order to allow the units to operate both with low outdoor temperature in cooling mode and with high outdoor temperature in heating mode

2. Electric control and monitoring panel. This is housed in a metal casing in which the various electrical components are positioned on one metal plate.

2a. The power section includes:

- Main door-locking circuit-breaker.
- Fuse-holder that can be isolated with protection fuse triad for each compressor.
- Fuse-holder that can be isolated with protection fuse for compressor oil heaters and antifreeze (if installed).
- Control contactor for each compressor.
- Protection fuse for the ventilation unit.
- Fan speed regulating board.
- Contactor and magnetothermic switch to protect the pump (if the Hydronic Kit accessory is installed).
- Pump contactor (if the Hydronic Kit accessory is installed).
- Phase presence and sequence monitoring device on power supply

2b. The auxiliary section includes:

- Fuses on the auxiliary transformer.
- Fuses for fans protection
- Electromagnetic noise filter
- Adjusting fan speed board
- Insulating and safety transformer to power the auxiliary circuit.

2c. The microprocessor monitoring section includes:

- User interfacing terminal with display.
- On-off key.
- Operating mode selector key.
- Compressor on-off display **LED**.
- Operational mode **LED**
- Antifreeze heaters activated indicator **LED**.
- Fans on-off display **LED**
- Pumps on-off display **LED**
- Check-control with fault code display
- Defrosting, alarm, economy, stand-by **LED**.
- ON / Stand-by remote - Summer/Winter (E/I) remote selection (IP unit only).

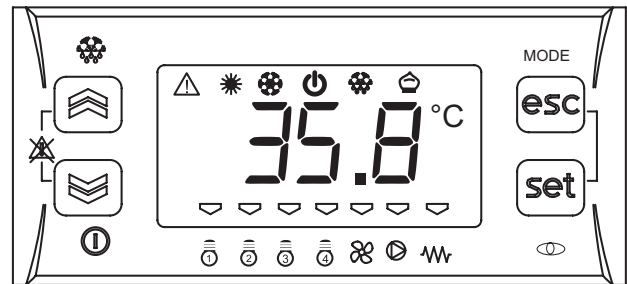

Control system main functions: temperature control of the water produced by the unit, compressor and pump operating hour counter, timing and cycling of start-ups, input parameters by keyboard, alarms management, smart defrosting control and operating mode change (only IP unit), dynamic set-point (climatic control), scheduling and integrative heaters control.

If you installed the hydronic kit these functions are enabled: antifreeze with pump, start-up cycle after prolonged inactivity (anti-sticking), if the hydronic kit installed has 2 pumps there is a cycling between each pump to ensure an equivalent lifetime, with inverter modulating hydronic kit the water flow of the plant can be adjusted.

Digital input functions: low pressure, high pressure, high temperature on compressor supply, phase presence and sequence monitoring device on power supply, differential water pressure control, compressors thermal protection, fans thermal protection, pumps thermal protection (only if installed MP accessory), ON/OFF and remote operating mode change, demand limit and Economy function, recovery enabling (only for the **VR** Version), recovery Pump Thermal Protective (only for the **VR** Version), recovery differential water pressure control (only for the **VR** Version).

Digital output functions: compressor start-up, pump start-up (only with MP accessory), plate heat exchanger electrical heater, remote general alarm, 4-way valve (only IP unit), integrative heaters and clean contact on compressors start-up, recovery valve management (only for the **VR** Version), recovery pump management (only for the **VR** Version).

Analogic input functions: in and out water temperature, coil temperature probe, external air temperature probe (if present), in and out recovery water temperature (only for the **VR** Version).

Analogic output functions: continuous adjustment of axial fans rotating speed, continuous adjustment of pump rotating speed.

GENERAL SPECIFICATIONS

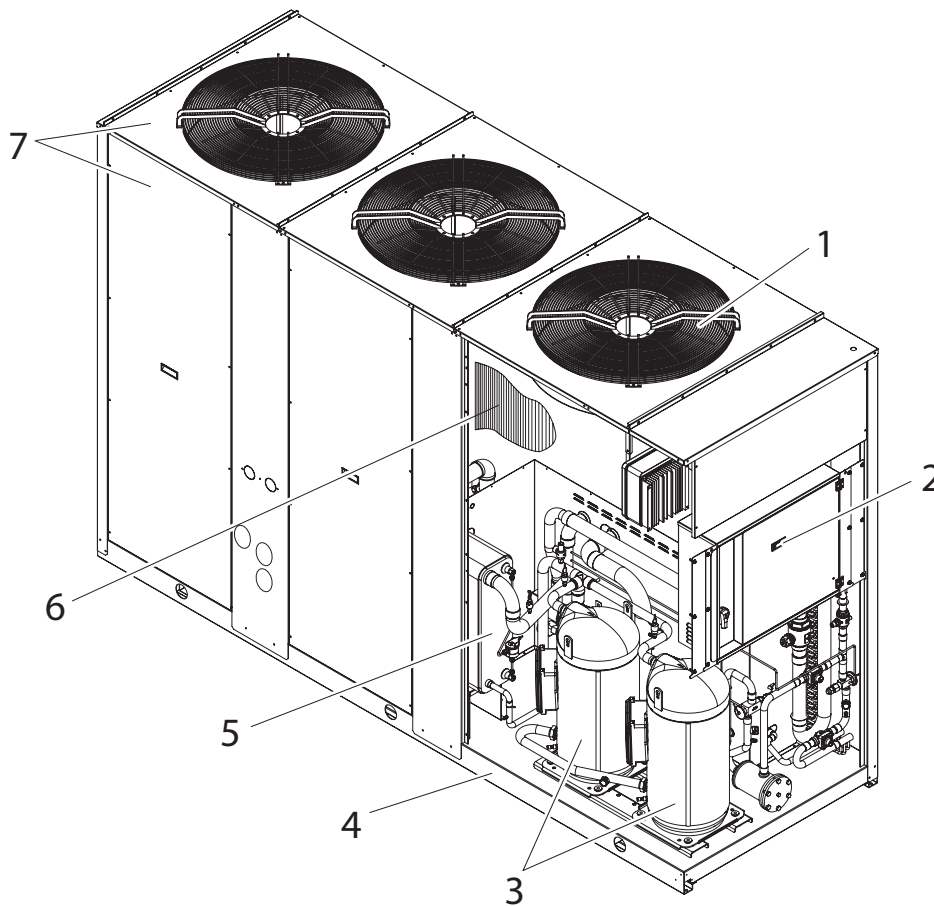

3. Compressors. They are the **SCROLL** type with orbiting coil equipped with built-in thermal protection and oil heater. The AS unit includes: a soundproofing jacket for the compressors, an acoustic cladding around the compartment where they are housed, to reduce noise level, and reduced rotating speed of axial fans; AX unit integrates batteries with condensing surface increased and rotating speed of axial fans further reduced. All units are equipped with two compressors connected in parallel (1 single cooling circuit) which can operate at the same time (**100% cooling power**) or individually (**50% of the cooling power**), thus adapting to the different thermal loads of the system supplied.

4. Frame structure made of galvanized sheet metal panels coated with polyurethane powder paint to ensure maximum protection against adverse weather conditions.

5. Evaporator made of brazed stainless steel plates (**AISI 316**). It is installed in a shell of heat-insulating material to prevent the formation of condensation and heat exchanges towards the outside. Standard supply also includes antifreeze heater a differential pressure switch on the water circuit to avoid the risk of freezing if the water flow is shut off for some reason.

6. Condensing coils, the aluminium finned pack type with shaped profile to increase the heat exchange coefficient and with copper pipes arranged in staggered rows. A sub-cooling section is integrated into the lower part.

7. Covering panels, made of galvanized sheet metal coated with polyurethane powder paint to ensure maximum protection against adverse weather conditions

8. One-way valves (IP unit only), allowing the coolant to pass into the appropriate exchangers, depending on the operating cycle.

9. 4-way cycle reversal valve (IP unit only), reverses the flow direction of the coolant as the summer/winter operating mode is changed.

GENERAL SPECIFICATIONS

Hydraulic and cooling circuit components

- 10. Safety valve.** Installed on the delivery pipe of the compressors, this operates if extreme faults should occur in the plant.
- 11. Fluid cock.** Ball type, this allows the gas flow on the fluid line to be turned on and off. Along with the cock on the compressor delivery, it allows the components of the fluid line to be subjected to extraordinary maintenance work and the compressors to be replaced if necessary (without discharging the coolant from the unit).
- 12. Compressor delivery cock.** Ball type, allows the gas delivered to the compressors to be turned on and off.
- 13. Dehydrator filter.** Mechanical type. Retains impurities and traces of moisture in the circuit. **Hermetic** type for models **50÷80**; **cartridge** type for models **90÷200**.
- 14. Fluid and humidity indicator.** Signals when fluid passes through the circuit, indicating that the coolant charge is correct. The fluid indicator light also indicates the amount of moisture in the coolant by changing colour.
- 15. Low pressure switch (N°1 of series IR version, N°2 of series IP version).** With fixed setting. It is installed on the suction pipe and blocks the compressors if the operating pressures drop below the tolerated values. Automatically resets as the pressure increases. If it activates frequently, the unit will block and can only be restarted by resetting via the user interface terminal.
- 16. High pressure switch (n°2).** With fixed setting. Are is installed on the delivery pipe and blocks the compressors if the operating pressures exceed the tolerated values. If it activates, the unit will block and can only be restarted by resetting via the user interface terminal.
- 17. Thermostatic valve.** With external equalizer, this supplies the evaporator correctly, keeping the selected overheating degree at a steady level.
- 18. Water differential pressure switch.** This is standard supply and is installed on the connections between the water inlet and outlet of the exchanger. It stops the unit if it activates.
- 19. Pressure taps: 1/4 " SAE (7/16" UNF) type with flow regulator.** Allow the operating pressure of the system to be measured: compressor delivery, lamination component inlet, compressor intake.
- 20. Pressure taps: 5/16 " SAE type with flow regulator.** Allow the charge/discharge of the gas from the system, precisely from compressor outlet an expansion valve inlet.
- 21. Electrical heating elements to heat the compressor oil.** "Belt" type. These activate when the compressor turns off and keep the temperature of the oil sufficiently high so as to prevent coolant from migrating during these pauses.
- Fluid receiver (IP unit only),** this is a plenum tank that accounts for variations to the coolant charge the machine must supply as the summer/winter operating mode varies.
- Fluid separator (IP unit only),** on the compressor intake to protect against possible fluid back-flows.

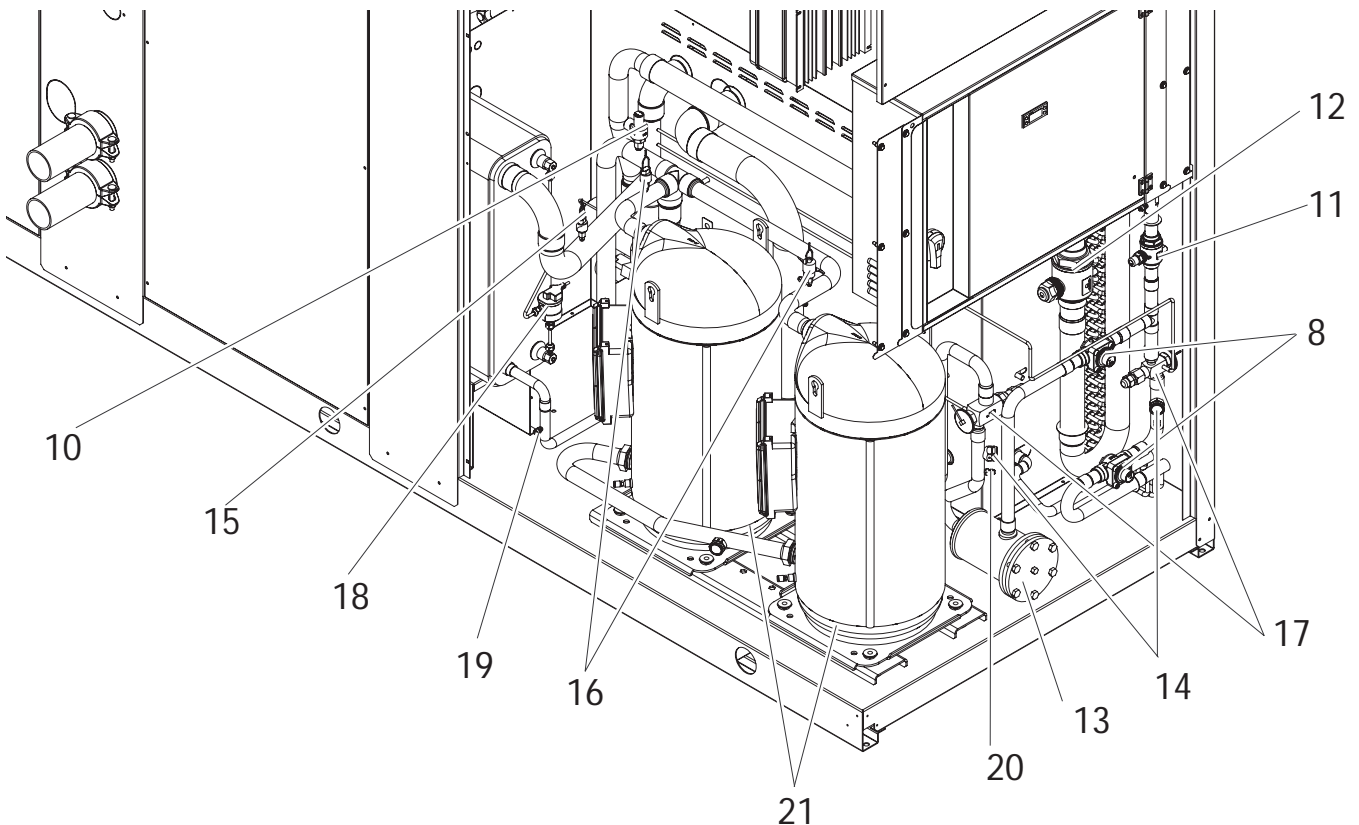

GENERAL SPECIFICATIONS

Desuperheater unit VD (available for both IR units and IP units)

Hydraulic and chilling circuit components:

- 1. Desuperheater.** Specially designed for the specific version. Plate type, made of stainless steel (AISI 316). It is installed within a shell of thermal barrier insulating material to prevent heat exchanges towards the outside. Standard supply also includes an electric antifreeze heater to prevent the parts from freezing during the winter, when the system remains at a standstill (if not drained).
- 2. Water safety valve.** On the heat recovery inlet pipe. It acts whenever faulty service leads to an operating pressure in the plumbing system that exceeds the valve opening value (Fig.1).
- 3. Water drain cock** for emptying the exchangers and pipes of the machine dedicated to heat recovery (Fig. 1).
- 4. Air vent.** Accessed by removing the front panels. It consists of a manually operated valve installed in the highest part of the water pipes. To use in conjunction with the water drain cocks situated in the rear part of the unit, for emptying the exchangers and pipes dedicated to heat recovery.

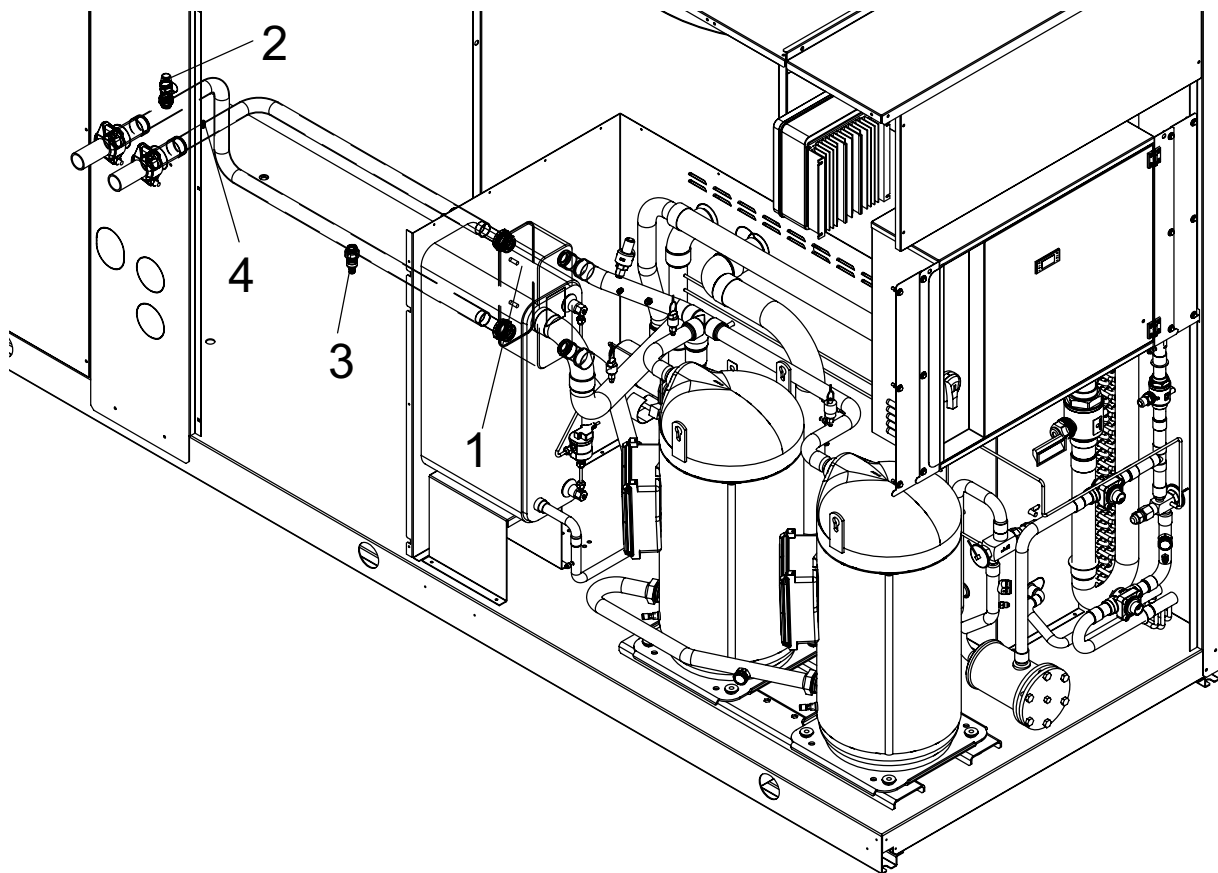

GENERAL SPECIFICATIONS

Total Heat Recovery unit VR (only available for IR units)

Hydraulic and cooling circuit components:

- 1. Heat recovery exchanger.** Specially designed for the specific version. Plate type, made of stainless steel (AISI 316). It is installed within a shell of thermal barrier insulating material to prevent heat dispersion towards the outside. Standard supply also includes an electric antifreeze heater to prevent the parts from freezing during the winter, if it is not drained.
- 2. Differential water pressure switch.** Installed on exchanger. It disables the heat recovery version if activated owing to lack of water flowing through the recovery exchangers.
- 3. Heat recovery management valve.** This delivers refrigerant to the condensing coils or heat recovery exchanger, depending on demands for hot water, and into the appropriate exchangers depending on whether hot water is required or not.
- 4. Fluid receiver.** This is a plenum tank that accounts for the refrigerant charge variations required by the machine as the operating modes change (condensing in air or in water).
- 5. One-way valves.** Make the refrigerant obligatorily pass through the appropriate heat exchangers (coils / heat exchanger), depending on the operating mode.

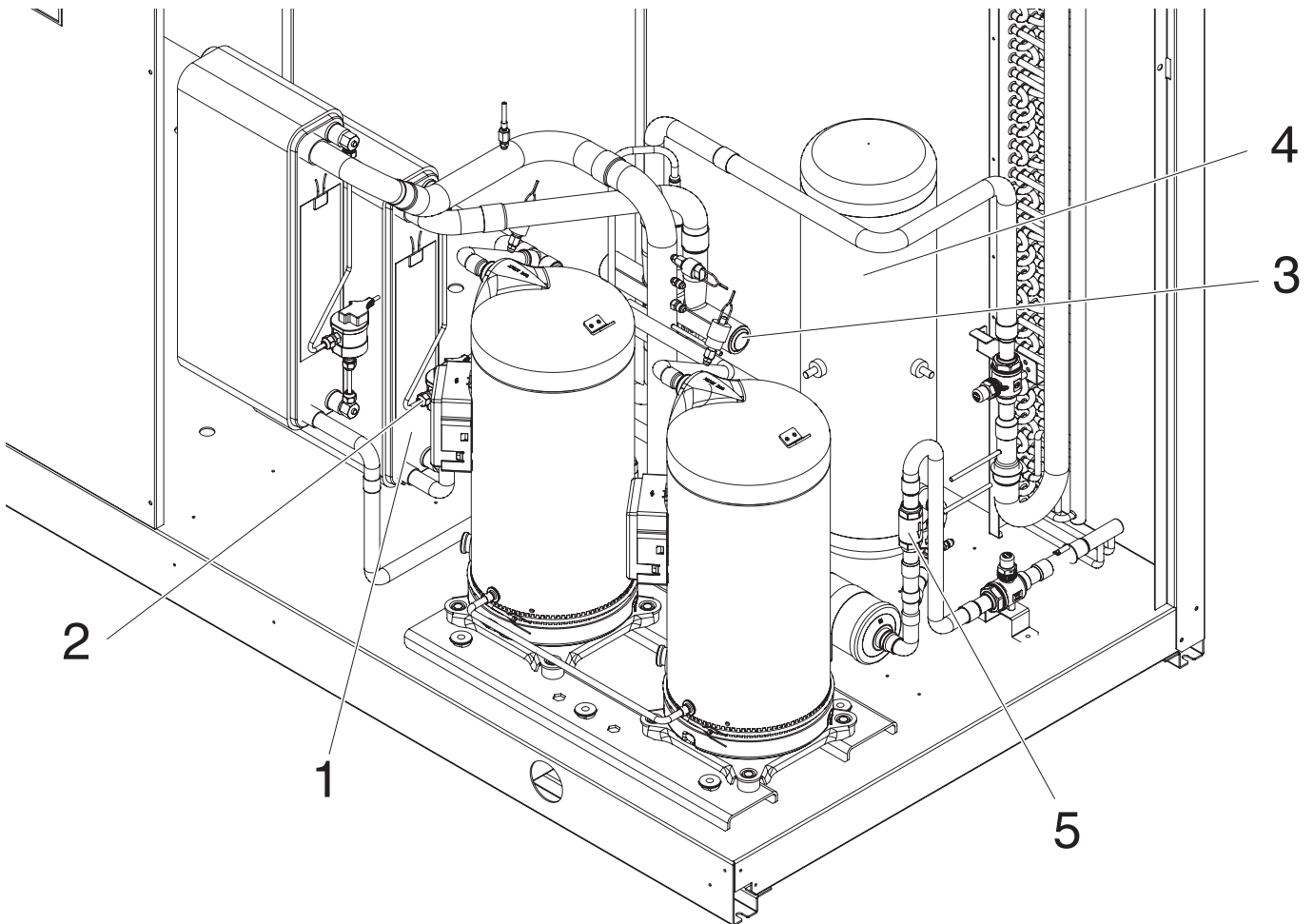

ACCESSORIES AND OPTIONAL EQUIPMENT

Accessories

AVG - Rubber vibration dampers. Consisting of 4/6 rubber vibration dampers to fit under the unit. Reduce the extent to which the mechanical vibrations created by the compressors and fans during normal operation are transmitted to the bearing surface of the machine. The insulating degree of the vibration dampers is about 85%.

GM - Pressure gauge unit. Consisting of 2 pressure gauges that display the pressure values of the refrigerating fluid on the compressor suction and delivery sides.

GP - Protective grilles. These are metal grilles installed to protect the finned banks.

SAA - Water storage tank. Made of adequately thick painted sheet metal, this reduces the number of compressor start-ups and fluctuations in the temperature of the water conveyed to the users. It is insulated with thermal barrier material to prevent the formation of condensation and heat exchanges towards the outside.

Water storage tank. It consists of:

Water draining. On-off action by means of a cock that can be accessed by removing the rear panel, positioned on the side of the unit opposite to the electric panel.

Air vent. Accessed by removing the rear panel positioned on the side of the unit opposite to the electric panel. It consists of a manually operated valve installed on the highest part of the wet pipes.

Antifreeze heater connection. 1"1/4 female threaded connection pre-engineered for installation of the antifreeze heater (RAG accessory).

Water safety valve, on the rear part of the tank. It acts whenever faulty service leads to an operating pressure in the hydraulic circuit that exceeds the valve opening value.

BCN- Drain Pan Kit (M). Provides a pan under the coil to drain the condensing water, fitted with 1/2" outlet connection positioned opposite to the electric control panel.

KT - the following kits are available (this accessory is mandatory if the Hydronic Kit is not installed).

- **Victaulic connection kit.** This accessory consists of steel pipes insulated with thermal barrier material and allows the water inlet/outlet to be connected straight inside the unit.

- **Complete pipe kit.** This accessory consists of steel pipes insulated with thermal barrier material and allows the water inlet/outlet connection to be routed to the machine.

- **Water storage tank pipe kit.** This accessory consists of steel pipes insulated with thermal barrier material and allows the water inlet/outlet connection to be routed to the machine.

NB: YOU CAN CHOOSE ONLY ONE KIT.

• **MP. Hydronic Kit (M).** Consists of:

1 On-off ball valves. Turn components such as the water filter, surge chamber and pump on and off when they require routine or extraordinary maintenance.

2 Metal gauze water filter. Can be turned on and off and inspected. It is installed on the pump delivery side. Prevents machining residues (dust, swarf, etc.) in the water pipes from entering the plate-type heat exchanger.

3 Hydraulic pump. Circulates water around the system. The pumps have a low/high head and suit the majority of installation requirements. The pumps are safeguarded by a magnetothermics installed in the chiller's electric panel.

4 Surge chamber. This is a closed, diaphragm type chamber. It absorbs the variations in the volumes of water in the system caused by temperature variations.

5 Water filling. Manual function with control positioned on the side of the unit opposite the electric panel and turned on and off by a cock that can be accessed by removing the rear panel.

6 Water pressure gauge. Connected to the water fill pipe. Displays the pressure of the water in the system.

7 Water safety valve.

8 Water outlet.

9 Air vent.

10 Antifreeze heater connection (RAG accessory).

ACCESSORIES AND OPTIONAL EQUIPMENT

MP. Hydronic Kit.

MP : Hydronic Kit with 1 o 2 Pumps (The second pump, mounted in parallel to the first, allows to have a spare pump to be activated in case of failure of the first). Besides the pumps, this accessory is equipped with all the hydraulic components (water filter, expansion tank, on-off valves, water pressure gauge, air vent, water outlet) required for complete installation and easy maintenance. **Different water accumulation tank configurations are therefore available in combination with the Hydronic Kit accessory:**

MP1 / MP2 AM 2P STD: Accumulation on the Plant Delivery side (Standard)^(A): The pump draws water from the system, sends it to the plate exchanger and from thence to the inertial accumulation tank. During normal operating conditions, the pump in this configuration is able to provide a residue head from 86 to 150 kPa (from 9 to 15 m.w.c.) for the circulating water.

MP1 / MP2 AM 2P HP1: Accumulation on the Plant Delivery side (High)^(B): The pump draws water from the system, sends it to the plate exchanger and from thence to the inertial accumulation tank. During normal operating conditions, the pump in this configuration is able to provide a residue head from 198 to 255 kPa (from 20 to 25 m.w.c.) for the circulating water.

MP1 / MP2 PS 2P STD: Accumulation pre-engineered for the primary and secondary circuit : The sole function of the pump is to circulate the water around the primary circuit: this circuit includes the accumulation tank and plate exchanger (chiller water circuit). The installer must mount the pumping section relative to the secondary circuit formed by the accumulation tank (with the pre-engineered wet connections) and the system served. No high working head version available.

MP1 / MP2 SS 2P STD: Hydronic Kit without Water Storage Tank (Standard)^(A). The pump draws water from the system, sends it to the plate heat exchanger and returns it to the system. During normal operating conditions, the pump in this configurations can provide a residue head from 86 to 150 kPa (from 9 to 15 m w.c.).

MP1 / MP2 SS 2P HP1: Hydronic Kit without Water Storage Tank (High Working Head)^(B). The pump draws water from the system, sends it to the plate heat exchanger and returns it to the system. During normal operating conditions, the pump in this configurations can provide a residue head from 198 to 255 kPa (from 20 to 25 m w.c.).

MP1M AM 2P STD: Accumulation on the Plant Delivery side (Standard)^(A): The pump draws water from the system, sends it to the plate exchanger and from thence to the inertial accumulation tank. During normal operating conditions, the pump in this configuration is able to provide a residue head from 86 to 150 kPa (from 9 to 15 m.w.c.) for the circulating water. The **Inverter** control enables the calibration of the plant water flow directly from the control panel permitting: energy savings compared to a traditional setting, reduction of water hammer in the pipes thanks to gradual start-ups and shutdowns, noise reduction of the pump, reducing starting current and improved thermal protection against overload.

MP1M AM 2P HP1: Accumulation on the Plant Delivery side (High)^(B): The pump draws water from the system, sends it to the plate exchanger and from thence to the inertial accumulation tank. During normal operating conditions, the pump in this configuration is able to provide a residue head from 198 to 255 kPa (from 20 to 25 m.w.c.) for the circulating water. The **Inverter** control enables the calibration of the plant water flow directly from the control panel permitting: energy savings compared to a traditional setting, reduction of water hammer in the pipes thanks to gradual start-ups and shutdowns, noise reduction of the pump, reducing starting current and improved thermal protection against overload.

MP1M SS 2P STD: Hydronic Kit without Water Storage Tank (Standard)^(A). The pump draws water from the system, sends it to the plate heat exchanger and returns it to the system. During normal operating conditions, the pump in this configurations can provide a residue head from 86 to 150 kPa (from 9 to 15 m w.c.). The **Inverter** control enables the calibration of the plant water flow directly from the control panel permitting: energy savings compared to a traditional setting, reduction of water hammer in the pipes thanks to gradual start-ups and shutdowns, noise reduction of the pump, reducing starting current and improved thermal protection against overload.

MP1M SS 2P HP1: Hydronic Kit without Water Storage Tank (High Working Head)^(B). The pump draws water from the system, sends it to the plate heat exchanger and returns it to the system. During normal operating conditions, the pump in this configurations can provide a residue head from 198 to 255 kPa (from 20 to 25 m w.c.). The **Inverter** control enables the calibration of the plant water flow directly from the control panel permitting: energy savings compared to a traditional setting, reduction of water hammer in the pipes thanks to gradual start-ups and shutdowns, noise reduction of the pump, reducing starting current and improved thermal protection against overload.

(A): For the working head values depending on the water flow rate, consult the Standard Working Head MP-AM graph.

(B): For the working head values depending on the water flow rate, consult the High Working Head MP-AM graph.

NOTE: (M): Installed **(F):** To be installed by customers

NOTE: It is essential to purchase the units with either the KT or MP accessory described previously. The choice of one automatically excludes the other.

ACCESSORIES AND OPTIONAL EQUIPMENT

VICTAULIC CONNECTION KIT

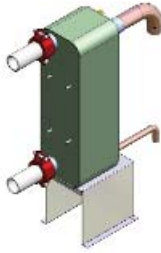

COMPLETE PIPE KIT

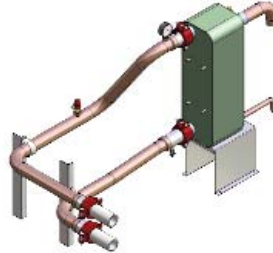

WATER STORAGE TANK PIPE KIT

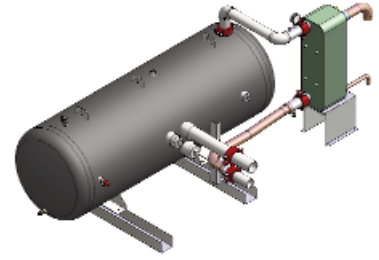

M1P AM 2P STD

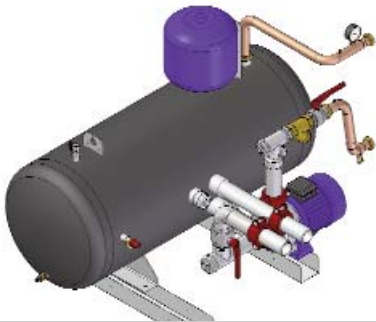

M1P AM 2P HP1

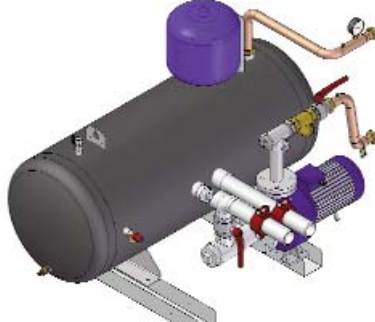

M1P PS 2P STD

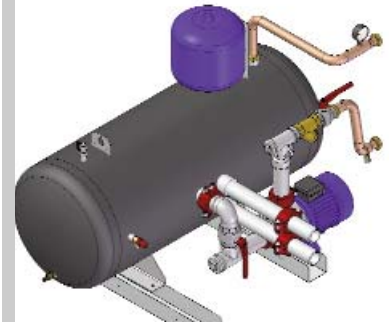

M2P AM 2P STD

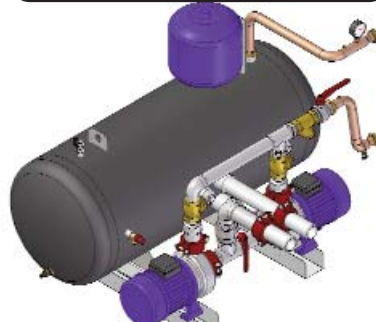

M2P AM 2P HP1



M2P PS 2P STD

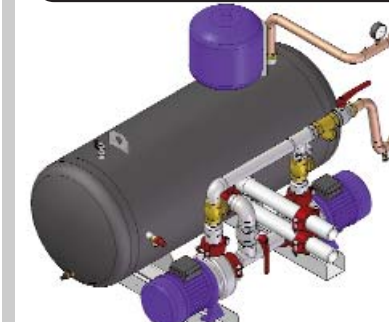

M1P SS 2P STD

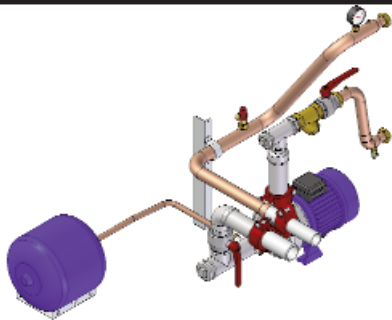

M1P SS 2P HP1

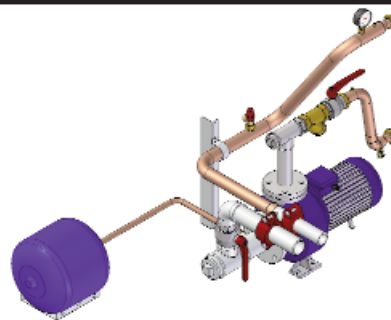

M2P SS 2P STD

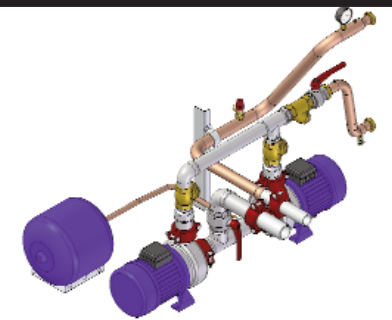

M2P SS 2P HP1

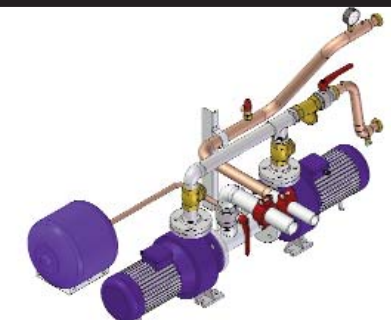

ACCESSORIES AND OPTIONAL EQUIPMENT

CR - Remote control (F). This can be used to select all the monitoring and display functions of the control unit on the machine at a maximum distance of 100 meters away. It must be installed by using a cable with three strands or three wires in **PVC** of the **N07-VK** type with a 1mm² section. The transmission line must be installed in a race-way separate from any electric powering wires (**230/400 V**).

The control unit has the following buttons:

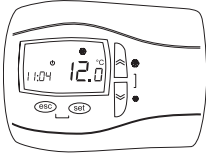

MODE key : used to select the operating mode

ON/OFF key : used to turn the unit ON/OFF and to reset the alarms

Mode + ON/OFF keys : used to access and quit the various menu levels

UP key: scrolls forwards through the menu items or increases the value of a parameter

Tasto DOWN: scrolls backwards through the menu items or decreases the value of a parameter.

KOP - Programmer clock (F). Allows the unit to be turned on and off depending on the programmed time setting (up to 14 switching actions can be programmed as required throughout the 7 days of the week).

RAG: Antifreeze heating element for the accumulation tank (M/F). Plug type. This activates in parallel with the evaporator's antifreeze heating element and keeps the water at a temperature able to prevent ice from forming when the unit remains idle during the winter.

TAT- High Temperature Thermostat (M). Two thermostats in series on compressors outlet pipes preserve operation not allowing temperature to rise up than a specified non adjustable value.

SND- External Air Probe (M). External air probe mounted near coil allows smart defrosting, climatic variation of setpoint and enables heat pump stop reducing the external air temperature below a setpoint.

INT - Serial interface (F). Allows serial communication on RS485 by MODBUS protocol

FLS - Flow switch (F). Paddle flow switch on the water circuit to avoid the risk of freezing if the water flow is shut off for some reason.

SS - Soft Starter (M). Soft starter for compressor, reduce the maximum starting current up to 60% of nominal starting current.

RIF - Capacitors for power factor corrections (M). Capacitors for power factor corrections increase power factor $\cos \varphi$ (>0.91) and reduce power input.

MTC - Magnetothermic switch (M). Magnetothermic switch on all loads place of fuses.

CSF - Voltage monitor and sequence meter (M). The device enables control of the correct sequence of power phases and the lack of any phases. It also ensures that the unit works within $\pm 10\%$ the rated voltage (MIN=360 V - RATED=400V - MAX=440V). It blocks the unit if the voltage is outside the limits provided for.

NOTE: (M): Installed **(F):** To be installed by customers

Mechanical options

Special finned heat exchangers

- Coils with copper fins
- Coils with tin-coated copper fins
- Coils with aluminium fins with acrylic, epoxy or hydrophilic coating.

Electrical options

Other power source voltage rating (contact our technical department).

TECHNICAL SPECIFICATIONS AND STANDARD PERFORMANCES - IR COOLING UNIT ONLY

Technical specifications of unit AB Standard Unit

Model	50	60	70	80	90	100	115	130	145	160	180	200	UM	
Power supply	400V - 3ph+N - 50 Hz					400V - 3ph - 50 Hz							V-f-Hz	
Type of refrigerant	R410A													/
Circuits	1													n°
Cooling capacity (1) (E)	53.5	58.6	68.8	78.7	91.0	102	112	126	143	158	180	200	kW	
Compressors power input (1)	16.5	18.5	21.7	25.6	28.2	31.6	35.5	40.5	45.0	50.5	56.0	62.8	kW	
Compressor EER	3.24	3.17	3.17	3.07	3.23	3.23	3.15	3.11	3.18	3.13	3.21	3.18	-	
Total power input (1)	18.3	20.3	23.5	27.4	31.8	35.2	39.1	44.1	50.4	55.9	63.2	70.0	kW	
Total EER (E)	2.92	2.89	2.93	2.87	2.86	2.90	2.86	2.86	2.84	2.83	2.85	2.86	-	
ESEER (E)	4.03	3.98	4.04	3.96	3.95	4.00	3.95	3.94	3.92	3.90	3.93	3.94	-	
Water flow rate (1)	2.56	2.80	3.29	3.76	4.35	4.87	5.35	6.02	6.83	7.55	8.60	9.56	l/s	
Water pressure drops (1) (E)	42	51	48	40	40	40	40	39	39	39	58	57	kPa	
Available static head (1) (MP)	135	116	97	75	143	129	113	92	116	95	141	107	kPa	

Compressor

Type	Scroll													/
Quantity	2													n°
Load steps	0-50-100													%
Oil charge CP1	3.25	3.25	3.25	3.25	3.25	4.7	4.7	6.8	6.8	6.3	6.3	6.3	l	
Oil charge CP2	3.25	3.25	3.25	3.25	4.7	4.7	6.8	6.8	6.3	6.3	6.3	6.3	l	

Heat Exchanger

Type	Brazen plates													/
Quantity	1													n°
Water volume	3.6	3.6	4.6	5.4	7.6	8.4	9.7	10.9	12.6	14.5	11.1	13.0	l	

Fan

Type	Axial													-	
Quantity	3			2				3		4				n°	
Maximum rotational speed ^(AB)	900													rpm	
Total air flow rate	29050	29050	28100	27680	41460	40100	47440	47440	62190	59820	82920	79760	m³/h		
Power input	1.8				3.6				5.4		7.2				kW

Coil

Type	Aluminum fins and copper tubes													/
Quantity	1													n°
Front area	3.38				4.72				5.90				7.41	m²

Water Storage Tank (SAA accessory)

Water volume	200				400				460				l	
Safety valve setting	600													kPa
Surge chamber volume	12				24								l	
Surge chamber default pressure	150													kPa
Max. operating pressure	1000				800								kPa	

Electrical Data

Units without hydronic kit

Total maximum power input [FLA]	48.2	50.9	58.3	68.6	76.0	81.5	89.9	98.3	117	131	150	165	A
Total maximum power input [FLI]	25.5	27.7	31.1	35.5	43.6	49.2	53.9	58.6	69.4	78.2	90.8	101	kW
Total maximum starting current [MIC]	146	147	173	211	265	270	317	325	368	382	470	485	A

Units with hydronic kit MP PS STD (1 or 2 pumps)

Total maximum power input [FLA]	50.7	53.4	60.8	71.1	79.4	84.9	93.3	102	122	136	157	171	A
Total maximum power input [FLI]	26.8	29.0	32.4	36.8	45.4	51.0	55.7	60.4	72.3	81.1	94.6	105	kW
Total maximum starting current [MIC]	148	149	175	213	268	273	320	329	373	387	477	491	A

Units with hydronic kit MP AM STD and MP SS STD (1 or 2 pumps)

Total maximum power input [FLA]	51.4	54.1	61.5	71.8	80.8	86.3	94.7	103	123	137	158	173	A
Total maximum power input [FLI]	27.2	29.4	32.8	37.2	46.5	52.1	56.8	61.5	72.7	81.5	95.6	106	kW
Total maximum starting current [MIC]	149	150	176	214	269	275	322	330	373	388	479	493	A

Units with hydronic kit MP AM HP1 and MP SS HP1 (1 or 2 pumps)

Total maximum power input [FLA]	54.4	57.1	64.6	74.9	82.2	87.8	98.1	106	125	140	161	176	A
Total maximum power input [FLI]	29.2	31.4	34.8	39.2	47.3	53.0	58.7	63.4	74.2	83.0	97.3	108	kW
Total maximum starting current [MIC]	152	153	179	217	271	276	325	334	376	390	481	496	A

Data referred to standard operating condition.

(1): water temperature: in 12°C - out 7°C air temperature: in 35°C d.b.

(2): water temperature: in 40°C - out 45°C air temperature: in 7°C d.b. 87% RH

(MP): with standard hydronic kit MP AM STD and MP SS STD

(SAA): with storage tank

(E): data declared according to LCP EUROVENT certification program

TECHNICAL SPECIFICATIONS AND STANDARD PERFORMANCES - IR COOLING UNIT ONLY

Standard performances AB Standard unit

Mod. 50-100

MOD.	Tw	OUTDOOR AIR TEMPERATURE (°C D.B.)													
		20		25		30		35		40		45		50	
		kWf	kWa	kWf	kWa	kWf	kWa	kWf	kWa	kWf	kWa	kWf	kWa	kWf	kWa
50	5	61.1	11.6	57.0	13.3	53.9	14.7	50.6	16.2	47.1	17.8	43.6	19.4	40.0	21.0
	6	62.8	11.7	58.6	13.4	55.4	14.8	52.0	16.3	48.4	18.0	44.8	19.6	41.1	21.2
	7	64.6	11.8	60.3	13.6	57.0	15.0	53.5	16.5	49.8	18.2	46.1	19.8	42.3	21.4
	8	66.4	11.9	62.0	13.7	58.6	15.1	55.0	16.7	51.2	18.4	47.4	20.0	-	-
	9	68.2	12.1	63.7	13.9	60.2	15.3	56.5	16.8	52.6	18.6	48.7	20.2	-	-
	10	70.1	12.2	65.4	14.0	61.8	15.4	58.0	17.0	54.0	18.8	50.0	20.4	-	-
	11	71.8	12.3	67.1	14.1	63.4	15.6	59.5	17.2	55.4	18.9	51.3	20.6	-	-
	12	73.8	12.4	68.9	14.3	65.1	15.7	61.1	17.4	56.9	19.1	52.7	20.8	-	-
60	5	66.9	13.0	62.4	14.9	59.0	16.5	55.4	18.1	51.5	20.0	47.7	21.8	43.9	23.6
	6	68.7	13.1	64.2	15.1	60.7	16.6	56.9	18.3	53.0	20.2	49.1	22.0	45.1	23.8
	7	70.7	13.2	66.0	15.2	62.4	16.8	58.6	18.5	54.5	20.4	50.5	22.2	46.4	24.0
	8	72.8	13.4	67.9	15.4	64.2	17.0	60.3	18.7	56.1	20.6	51.9	22.5	-	-
	9	74.8	13.5	69.8	15.6	66.0	17.1	61.9	18.9	57.6	20.8	53.4	22.7	-	-
	10	76.7	13.7	71.6	15.7	67.7	17.3	63.6	19.1	59.1	21.0	54.8	22.9	-	-
	11	78.7	13.8	73.5	15.9	69.5	17.5	65.2	19.3	60.7	21.2	56.2	23.2	-	-
	12	80.8	13.9	75.5	16.0	71.3	17.6	67.0	19.5	62.3	21.4	57.7	23.4	-	-
70	5	78.5	15.2	73.3	17.5	69.3	19.3	65.0	21.3	60.5	23.5	56.1	25.6	51.5	27.6
	6	80.7	15.4	75.3	17.7	71.2	19.5	66.9	21.5	62.2	23.7	57.6	25.8	52.9	27.9
	7	83.1	15.5	77.5	17.9	73.3	19.7	68.8	21.7	64.0	23.9	59.3	26.1	54.5	28.2
	8	85.4	15.7	79.7	18.1	75.4	19.9	70.7	21.9	65.8	24.2	61.0	26.4	-	-
	9	87.8	15.9	81.9	18.2	77.5	20.1	72.7	22.2	67.6	24.4	62.6	26.6	-	-
	10	90.1	16.0	84.1	18.4	79.5	20.3	74.6	22.4	69.4	24.7	64.3	26.9	-	-
	11	92.4	16.2	86.2	18.6	81.6	20.5	76.5	22.6	71.2	24.9	66.0	27.2	-	-
	12	94.9	16.3	88.6	18.8	83.8	20.7	78.6	22.8	73.1	25.2	67.7	27.4	-	-
80	5	89.8	18.0	83.9	20.7	79.3	22.8	74.4	25.1	69.2	27.7	64.1	30.2	58.9	32.6
	6	92.3	18.1	86.2	20.9	81.5	23.0	76.5	25.3	71.1	27.9	65.9	30.5	60.5	32.9
	7	95.0	18.3	88.7	21.1	83.9	23.2	78.7	25.6	73.2	28.2	67.8	30.8	62.3	33.3
	8	97.7	18.5	91.2	21.3	86.2	23.5	80.9	25.9	75.3	28.5	69.7	31.1	-	-
	9	100	18.7	93.7	21.5	88.6	23.7	83.2	26.1	77.4	28.8	71.7	31.4	-	-
	10	103	18.9	96.2	21.7	91.0	23.9	85.4	26.4	79.4	29.1	73.6	31.7	-	-
	11	106	19.1	98.7	21.9	93.3	24.2	87.5	26.7	81.5	29.4	75.4	32.0	-	-
	12	109	19.3	101	22.2	95.8	24.4	89.9	26.9	83.7	29.7	77.5	32.3	-	-
90	5	104	19.8	97.0	22.8	91.7	25.1	86.0	27.7	80.1	30.5	74.1	33.2	68.1	35.9
	6	107	20.0	100	23.0	94.2	25.3	88.4	27.9	82.3	30.8	76.2	33.5	70.0	36.3
	7	110	20.2	103	23.2	97.0	25.6	91.0	28.2	84.7	31.1	78.4	33.9	72.0	36.6
	8	113	20.4	105	23.5	100	25.9	93.6	28.5	87.1	31.4	80.6	34.3	-	-
	9	116	20.6	108	23.7	102	26.1	96.2	28.8	89.5	31.7	82.9	34.6	-	-
	10	119	20.8	111	23.9	105	26.4	98.7	29.1	91.8	32.1	85.1	34.9	-	-
	11	122	21.0	114	24.2	108	26.6	101	29.4	94.2	32.4	87.2	35.3	-	-
	12	126	21.2	117	24.4	111	26.9	104	29.7	96.7	32.7	89.6	35.6	-	-
100	5	116	22.2	109	25.5	103	28.1	96.4	31.0	89.7	34.2	83.1	37.2	76.3	40.3
	6	120	22.4	112	25.7	106	28.4	99.1	31.3	92.2	34.5	85.4	37.6	78.4	40.6
	7	123	22.6	115	26.0	109	28.7	102	31.6	94.9	34.8	87.9	38.0	80.7	41.1
	8	127	22.9	118	26.3	112	29.0	105	31.9	97.6	35.2	90.4	38.4	-	-
	9	130	23.1	121	26.6	115	29.3	108	32.3	100	35.6	92.9	38.8	-	-
	10	134	23.3	125	26.8	118	29.6	111	32.6	103	35.9	95.3	39.2	-	-
	11	137	23.5	128	27.1	121	29.8	113	32.9	106	36.3	97.8	39.5	-	-
	12	141	23.8	131	27.4	124	30.1	117	33.2	108	36.6	100	39.9	-	-

Tw= Outlet water temperature °C

kWf = refrigerating power (kW).

kWa = Power input of compressors (kW)

The standard performances refer to a 5°C temperature difference between the water entering and leaving the plate-type heat exchanger and to operation of the unit with all fans at top speed. A $0.44 \times 10^{-4} \text{ m}^2 \text{ kW}$ fouling factor has also been considered with the unit installed at zero meters above sea level (Pb = 1013mbar).

TECHNICAL SPECIFICATIONS AND STANDARD PERFORMANCES - IR COOLING UNIT ONLY

Mod. 115-200

MOD.	Tw	OUTDOOR AIR TEMPERATURE (°C D.B.)													
		20		25		30		35		40		45		50	
		kWf	kWa	kWf	kWa	kWf	kWa	kWf	kWa	kWf	kWa	kWf	kWa	kWf	kWa
115	5	128	24.9	119	28.7	113	31.6	106	34.8	98.5	38.4	91.3	41.8	83.8	45.2
	6	131	25.1	123	28.9	116	31.9	109	35.1	101	38.7	93.8	42.2	86.1	45.7
	7	135	25.4	126	29.2	119	32.2	112	35.5	104	39.1	96.5	42.7	88.6	46.1
	8	139	25.7	130	29.5	123	32.6	115	35.9	107	39.6	99.2	43.1	-	-
	9	143	25.9	133	29.8	126	32.9	118	36.3	110	40.0	102	43.6	-	-
	10	147	26.2	137	30.1	129	33.2	121	36.6	113	40.4	105	44.0	-	-
	11	150	26.5	140	30.4	133	33.5	125	37.0	116	40.7	107	44.4	-	-
	12	154	26.7	144	30.7	136	33.9	128	37.3	119	41.1	110	44.9	-	-
130	5	144	28.4	134	32.7	127	36.0	119	39.7	111	43.8	103	47.7	94.3	51.6
	6	148	28.7	138	33.0	130	36.4	122	40.1	114	44.2	106	48.2	96.9	52.1
	7	152	29.0	142	33.3	134	36.7	126	40.5	117	44.6	109	48.7	100	52.6
	8	156	29.3	146	33.7	138	37.1	130	40.9	121	45.1	112	49.2	-	-
	9	161	29.6	150	34.0	142	37.5	133	41.4	124	45.6	115	49.7	-	-
	10	165	29.9	154	34.4	146	37.9	137	41.8	127	46.0	118	50.2	-	-
	11	169	30.2	158	34.7	149	38.3	140	42.2	130	46.5	121	50.7	-	-
	12	174	30.5	162	35.1	153	38.6	144	42.6	134	46.9	124	51.2	-	-
145	5	163	31.6	152	36.3	144	40.0	135	44.1	126	48.6	117	53.0	107	57.3
	6	168	31.9	157	36.7	148	40.4	139	44.5	129	49.1	120	53.5	110	57.9
	7	173	32.2	161	37.0	152	40.8	143	45.0	133	49.6	123	54.1	113	58.5
	8	178	32.6	166	37.5	157	41.3	147	45.5	137	50.1	127	54.7	-	-
	9	182	32.9	170	37.8	161	41.7	151	46.0	141	50.6	130	55.2	-	-
	10	187	33.2	175	38.2	165	42.1	155	46.4	144	51.2	134	55.8	-	-
	11	192	33.5	179	38.6	170	42.5	159	46.9	148	51.7	137	56.3	-	-
	12	197	33.9	184	39.0	174	42.9	163	47.3	152	52.2	141	56.9	-	-
160	5	180	35.4	168	40.8	159	44.9	149	49.5	139	54.6	129	59.5	118	64.3
	6	185	35.8	173	41.2	164	45.3	154	50.0	143	55.1	132	60.1	122	64.9
	7	191	36.1	178	41.6	168	45.8	158	50.5	147	55.7	136	60.7	125	65.6
	8	196	36.5	183	42.0	173	46.3	162	51.1	151	56.3	140	61.4	-	-
	9	202	36.9	188	42.5	178	46.8	167	51.6	155	56.8	144	62.0	-	-
	10	207	37.3	193	42.9	183	47.2	171	52.1	159	57.4	148	62.6	-	-
	11	212	37.6	198	43.3	187	47.7	176	52.6	164	58.0	151	63.2	-	-
	12	218	38.0	203	43.7	192	48.2	181	53.1	168	58.5	156	63.8	-	-
180	5	205	39.3	192	45.2	181	49.8	170	54.9	158	60.5	147	66.0	135	71.4
	6	211	39.7	197	45.6	186	50.3	175	55.4	163	61.1	151	66.6	138	72.0
	7	217	40.1	203	46.1	192	50.8	180	56.0	167	61.7	155	67.3	142	72.8
	8	223	40.5	209	46.6	197	51.4	185	56.6	172	62.4	160	68.0	-	-
	9	230	40.9	214	47.1	203	51.9	190	57.2	177	63.0	164	68.7	-	-
	10	236	41.3	220	47.5	208	52.4	195	57.8	182	63.7	168	69.4	-	-
	11	242	41.7	226	48.0	213	52.9	200	58.3	186	64.3	173	70.1	-	-
	12	248	42.1	232	48.5	219	53.4	206	58.9	191	64.9	177	70.8	-	-
200	5	228	44.1	213	50.7	202	55.9	189	61.6	176	67.9	163	74.0	150	80.0
	6	235	44.5	219	51.2	207	56.4	194	62.2	181	68.5	167	74.7	154	80.8
	7	241	44.9	225	51.7	213	57.0	200	62.8	186	69.2	172	75.5	158	81.6
	8	248	45.4	232	52.3	219	57.6	206	63.5	191	70.0	177	76.3	-	-
	9	255	45.9	238	52.8	225	58.2	211	64.1	197	70.7	182	77.1	-	-
	10	262	46.3	244	53.3	231	58.7	217	64.8	202	71.4	187	77.8	-	-
	11	269	46.8	251	53.8	237	59.3	222	65.4	207	72.1	192	78.6	-	-
	12	276	47.2	258	54.4	244	59.9	229	66.0	213	72.8	197	79.4	-	-

Tw= Outlet water temperature °C

kWf = refrigerating power (kW).

kWa = Power input of compressors (kW)

The standard performances refer to a 5°C temperature difference between the water entering and leaving the plate-type heat exchanger and to operation of the unit with all fans at top speed. A $0.44 \times 10^{-4} \text{ m}^2 \text{ K/W}$ fouling factor has also been considered with the unit installed at zero meters above sea level (Pb = 1013mbar).

TECHNICAL SPECIFICATIONS AND STANDARD PERFORMANCES - IR COOLING UNIT ONLY

Technical specifications of unit AS Low noise unit

Model	50	60	70	80	90	100	115	130	145	160	180	200	UM
Power supply	400V - 3ph+N - 50 Hz				400V - 3ph - 50 Hz								V-f-Hz
Type of refrigerant	R410A												/
Circuits	1												n°
Cooling capacity (1) (E)	51.9	56.8	66.7	76.3	88.2	98.5	109	122	139	153	174	194	kW
Compressors power input (1)	17.2	19.3	22.6	26.8	29.5	33.0	37.1	42.3	47.0	52.7	58.5	65.6	kW
Compressor EER	3.01	2.94	2.95	2.85	2.99	2.98	2.94	2.88	2.96	2.90	2.97	2.96	-
Total power input (1)	19.0	21.1	24.4	28.6	33.1	36.6	40.7	45.9	52.4	58.1	65.7	72.8	kW
Total EER (E)	2.73	2.69	2.73	2.67	2.66	2.69	2.68	2.66	2.65	2.63	2.65	2.66	-
ESEER (E)	3.76	3.71	3.77	3.68	3.68	3.71	3.70	3.67	3.66	3.63	3.65	3.68	-
Water flow rate (1)	2.48	2.71	3.19	3.65	4.21	4.71	5.21	5.83	6.64	7.31	8.31	9.27	l/s
Water pressure drops (1) (E)	39	48	45	38	37	37	38	37	37	37	54	54	kPa
Available static head (1) (MP)	144	124	103	80	153	138	119	98	123	101	151	114	kPa

Compressor

Type	Scroll												/
Quantity	2												n°
Load steps	0-50-100												%
Oil charge CP1	3.25	3.25	3.25	3.25	3.25	4.7	4.7	6.8	6.8	6.3	6.3	6.3	l
Oil charge CP2	3.25	3.25	3.25	3.25	4.7	4.7	6.8	6.8	6.3	6.3	6.3	6.3	l

Heat Exchanger

Type	Brazen plates												/
Quantity	1												n°
Water volume	3.6	3.6	4.6	5.4	7.6	8.4	9.7	10.9	12.6	14.5	11.1	13.0	l

Fan

Type	Axial												-
Quantity	3			2			3			4			n°
Maximum rotational speed	900												rpm
Total air flow rate	24208	24208	23417	23067	34550	33417	39533	39533	51825	49850	69100	66467	m³/h
Power input	1.8			3.6			5.4			7.2			kW

Coil

Type	Aluminum fins and copper tubes												/
Quantity	1												n°
Front area	3.38			4.72			5.90			7.41			m²

Water Storage Tank (SAA accessory)

Water volume	200			400			460			l			
Safety valve setting	600												kPa
Surge chamber volume	12			24			l						
Surge chamber default pressure	150												kPa
Max. operating pressure	1000			800			kPa						

Electrical Data

Units without hydronic kit

Total maximum power input [FLA]	48.2	50.9	58.3	68.6	76.0	81.5	89.9	98.3	117	131	150	165	A
Total maximum power input [FLI]	25.5	27.7	31.1	35.5	43.6	49.2	53.9	58.6	69.4	78.2	90.8	101	kW
Total maximum starting current [MIC]	146	147	173	211	265	270	317	325	368	382	470	485	A

Units with hydronic kit MP PS STD (1 or 2 pumps)

Total maximum power input [FLA]	50.7	53.4	60.8	71.1	79.4	84.9	93.3	102	122	136	157	171	A
Total maximum power input [FLI]	26.8	29.0	32.4	36.8	45.4	51.0	55.7	60.4	72.3	81.1	94.6	105	kW
Total maximum starting current [MIC]	148	149	175	213	268	273	320	329	373	387	477	491	A

Units with hydronic kit MP AM STD and MP SS STD (1 or 2 pumps)

Total maximum power input [FLA]	51.4	54.1	61.5	71.8	80.8	86.3	94.7	103	123	137	158	173	A
Total maximum power input [FLI]	27.2	29.4	32.8	37.2	46.5	52.1	56.8	61.5	72.7	81.5	95.6	106	kW
Total maximum starting current [MIC]	149	150	176	214	269	275	322	330	373	388	479	493	A

Units with hydronic kit MP AM HP1 and MP SS HP1 (1 or 2 pumps)

Total maximum power input [FLA]	54.4	57.1	64.6	74.9	82.2	87.8	98.1	106	125	140	161	176	A
Total maximum power input [FLI]	29.2	31.4	34.8	39.2	47.3	53.0	58.7	63.4	74.2	83.0	97.3	108	kW
Total maximum starting current [MIC]	152	153	179	217	271	276	325	334	376	390	481	496	A

Data referred to standard operating condition.

(1): water temperature: in 12°C - out 7°C air temperature: in 35°C d.b.

(2): water temperature: in 40°C - out 45°C air temperature: in 7°C d.b. 87% RH

(MP): with standard hydronic kit MP AM STD and MP SS STD

(SAA): with storage tank

(E): data declared according to LCP EUROVENT certification program

TECHNICAL SPECIFICATIONS AND STANDARD PERFORMANCES - IR COOLING UNIT ONLY

Standard performances AS Low noise unit

Mod. 50-100

MOD.	Tw	OUTDOOR AIR TEMPERATURE (°C D.B.)													
		20		25		30		35		40		45		50	
		kWf	kWa	kWf	kWa	kWf	kWa	kWf	kWa	kWf	kWa	kWf	kWa	kWf	kWa
50	5	59.2	12.1	55.3	13.9	52.3	15.3	49.1	16.9	45.7	18.6	42.3	20.3	38.8	22.0
	6	60.9	12.2	56.8	14.0	53.7	15.5	50.4	17.1	46.9	18.8	43.5	20.5	39.9	22.2
	7	62.7	12.3	58.5	14.2	55.3	15.6	51.9	17.2	48.3	19.0	44.7	20.7	41.1	22.4
	8	64.4	12.5	60.1	14.3	56.9	15.8	53.4	17.4	49.7	19.2	46.0	20.9	-	-
	9	66.2	12.6	61.8	14.5	58.4	16.0	54.8	17.6	51.0	19.4	47.3	21.1	-	-
	10	68.0	12.7	63.4	14.6	60.0	16.1	56.3	17.8	52.4	19.6	48.5	21.4	-	-
	11	69.7	12.8	65.1	14.8	61.5	16.3	57.7	17.9	53.7	19.8	49.8	21.6	-	-
	12	71.6	13.0	66.8	14.9	63.2	16.4	59.3	18.1	55.2	20.0	51.1	21.8	-	-
60	5	64.8	13.5	60.5	15.6	57.2	17.2	53.7	18.9	50.0	20.9	46.3	22.7	42.5	24.6
	6	66.6	13.7	62.2	15.7	58.8	17.3	55.2	19.1	51.3	21.1	47.6	23.0	43.7	24.8
	7	68.6	13.8	64.0	15.9	60.5	17.5	56.8	19.3	52.8	21.3	48.9	23.2	45.0	25.1
	8	70.5	14.0	65.8	16.1	62.2	17.7	58.4	19.5	54.3	21.5	50.3	23.4	-	-
	9	72.5	14.1	67.6	16.2	64.0	17.9	60.0	19.7	55.8	21.7	51.7	23.7	-	-
	10	74.4	14.2	69.4	16.4	65.7	18.1	61.6	19.9	57.3	21.9	53.1	23.9	-	-
	11	76.3	14.4	71.2	16.5	67.3	18.2	63.2	20.1	58.8	22.2	54.4	24.2	-	-
	12	78.4	14.5	73.1	16.7	69.2	18.4	64.9	20.3	60.4	22.4	55.9	24.4	-	-
70	5	76.1	15.9	71.1	18.3	67.2	20.1	63.1	22.2	58.7	24.5	54.3	26.7	49.9	28.8
	6	78.2	16.0	73.0	18.4	69.1	20.3	64.8	22.4	60.3	24.7	55.8	26.9	51.3	29.1
	7	80.5	16.2	75.2	18.6	71.1	20.5	66.7	22.6	62.1	25.0	57.5	27.2	52.8	29.4
	8	82.8	16.4	77.3	18.8	73.1	20.8	68.6	22.9	63.8	25.2	59.1	27.5	-	-
	9	85.1	16.5	79.4	19.0	75.1	21.0	70.5	23.1	65.6	25.5	60.7	27.8	-	-
	10	87.3	16.7	81.5	19.2	77.1	21.2	72.3	23.3	67.3	25.7	62.3	28.1	-	-
	11	89.6	16.9	83.6	19.4	79.1	21.4	74.2	23.6	69.0	26.0	63.9	28.3	-	-
	12	92.0	17.0	85.9	19.6	81.2	21.6	76.2	23.8	70.9	26.2	65.7	28.6	-	-
80	5	87.1	18.8	81.3	21.6	76.9	23.8	72.1	26.3	67.1	29.0	62.2	31.6	57.1	34.1
	6	89.5	19.0	83.5	21.8	79.0	24.1	74.1	26.5	69.0	29.2	63.9	31.9	58.7	34.5
	7	92.1	19.2	86.0	22.1	81.3	24.3	76.3	26.8	71.0	29.5	65.7	32.2	60.4	34.8
	8	94.7	19.4	88.4	22.3	83.6	24.6	78.5	27.1	73.0	29.9	67.6	32.6	-	-
	9	97.3	19.6	90.9	22.5	85.9	24.8	80.6	27.4	75.0	30.2	69.5	32.9	-	-
	10	100	19.8	93.3	22.8	88.2	25.1	82.8	27.6	77.0	30.5	71.3	33.2	-	-
	11	102	20.0	95.6	23.0	90.4	25.3	84.9	27.9	79.0	30.8	73.1	33.5	-	-
	12	105	20.2	98.2	23.2	92.9	25.6	87.2	28.2	81.1	31.1	75.1	33.9	-	-
90	5	101	20.7	94.0	23.8	88.9	26.2	83.4	28.9	77.6	31.9	71.9	34.8	66.0	37.6
	6	103	20.9	96.6	24.0	91.3	26.5	85.7	29.2	79.7	32.2	73.9	35.1	67.8	37.9
	7	106	21.1	99.4	24.3	94.0	26.8	88.2	29.5	82.1	32.5	76.0	35.4	69.8	38.3
	8	109	21.3	102	24.6	96.6	27.1	90.7	29.8	84.4	32.9	78.2	35.8	-	-
	9	113	21.6	105	24.8	99.3	27.3	93.2	30.1	86.7	33.2	80.3	36.2	-	-
	10	115	21.8	108	25.0	102	27.6	95.7	30.4	89.0	33.5	82.4	36.6	-	-
	11	118	22.0	111	25.3	105	27.9	98.1	30.7	91.3	33.9	84.5	36.9	-	-
	12	122	22.2	114	25.5	107	28.1	101	31.0	93.8	34.2	86.8	37.3	-	-
100	5	112	23.2	105	26.6	99.2	29.4	93.1	32.4	86.6	35.7	80.3	38.9	73.7	42.0
	6	116	23.4	108	26.9	102	29.6	95.7	32.7	89.0	36.0	82.5	39.3	75.8	42.4
	7	119	23.6	111	27.2	105	29.9	98.5	33.0	91.6	36.4	84.9	39.7	78.0	42.9
	8	122	23.9	114	27.5	108	30.3	101	33.4	94.2	36.8	87.3	40.1	-	-
	9	126	24.1	117	27.7	111	30.6	104	33.7	96.8	37.1	89.7	40.5	-	-
	10	129	24.3	120	28.0	114	30.9	107	34.0	99.4	37.5	92.1	40.9	-	-
	11	132	24.6	123	28.3	117	31.2	110	34.4	102	37.9	94.4	41.3	-	-
	12	136	24.8	127	28.6	120	31.5	113	34.7	105	38.2	97.0	41.7	-	-

Tw= Temperatura acqua in uscita in °C

kWf = Potenza frigorifera netta(kW).

kWa = Potenza assorbita dai compressori (kW)

Le prestazioni standard si riferiscono ad un differenza di 5 °C di temperatura tra acqua entrante ed uscente dallo scambiatore a piastre, e al funzionamento dell'unità con tutti i ventilatori alla massima velocità. Si considera inoltre un fattore di sporcamento di $0.44 \times 10^{-4} \text{ m}^2 \text{ K/W}$ e l'unità posta a zero metri sul livello del mare (Pb = 1013mbar).

TECHNICAL SPECIFICATIONS AND STANDARD PERFORMANCES - IR COOLING UNIT ONLY

Mod. 115-200

MOD.	Tw	OUTDOOR AIR TEMPERATURE (°C D.B.)													
		20		25		30		35		40		45		50	
		kWf	kWa	kWf	kWa	kWf	kWa	kWf	kWa	kWf	kWa	kWf	kWa	kWf	kWa
115	5	124	26.0	116	30.0	110	33.0	103	36.4	95.9	40.1	88.8	43.7	81.6	47.3
	6	128	26.3	119	30.2	113	33.3	106	36.7	98.5	40.5	91.3	44.1	83.8	47.7
	7	132	26.5	123	30.5	116	33.6	109	37.1	101	40.9	93.9	44.6	86.3	48.2
	8	135	26.8	126	30.9	119	34.0	112	37.5	104	41.3	96.6	45.1	-	-
	9	139	27.1	130	31.2	123	34.4	115	37.9	107	41.8	99.2	45.5	-	-
	10	143	27.4	133	31.5	126	34.7	118	38.3	110	42.2	102	46.0	-	-
	11	146	27.6	137	31.8	129	35.0	121	38.6	113	42.6	104	46.4	-	-
	12	150	27.9	140	32.1	133	35.4	125	39.0	116	43.0	107	46.9	-	-
130	5	139	29.7	130	34.1	123	37.6	115	41.5	107	45.7	99.4	49.8	91.3	53.9
	6	143	30.0	134	34.5	126	38.0	119	41.9	110	46.2	102	50.3	93.8	54.4
	7	147	30.3	137	34.8	130	38.4	122	42.3	114	46.6	105	50.8	96.6	55.0
	8	151	30.6	141	35.2	134	38.8	125	42.8	117	47.1	108	51.4	-	-
	9	156	30.9	145	35.6	137	39.2	129	43.2	120	47.6	111	51.9	-	-
	10	160	31.2	149	35.9	141	39.6	132	43.6	123	48.1	114	52.4	-	-
	11	164	31.5	153	36.3	145	40.0	136	44.1	126	48.6	117	52.9	-	-
	12	168	31.8	157	36.6	149	40.3	139	44.5	130	49.0	120	53.5	-	-
145	5	159	33.0	148	38.0	140	41.8	131	46.1	122	50.8	113	55.4	104	59.9
	6	163	33.3	152	38.3	144	42.2	135	46.5	126	51.3	116	55.9	107	60.5
	7	168	33.6	157	38.7	148	42.6	139	47.0	129	51.8	120	56.5	110	61.1
	8	173	34.0	161	39.1	152	43.1	143	47.5	133	52.4	123	57.1	-	-
	9	177	34.4	166	39.5	157	43.5	147	48.0	137	52.9	127	57.7	-	-
	10	182	34.7	170	39.9	161	44.0	151	48.5	140	53.4	130	58.3	-	-
	11	187	35.0	174	40.3	165	44.4	155	49.0	144	54.0	133	58.8	-	-
	12	192	35.4	179	40.7	169	44.8	159	49.4	148	54.5	137	59.4	-	-
160	5	175	37.0	163	42.6	154	46.9	145	51.7	135	57.0	125	62.1	114	67.2
	6	179	37.3	168	43.0	158	47.3	149	52.2	138	57.5	128	62.7	118	67.8
	7	185	37.7	172	43.4	163	47.8	153	52.7	142	58.1	132	63.4	121	68.5
	8	190	38.1	177	43.9	168	48.4	157	53.3	146	58.8	136	64.1	-	-
	9	195	38.5	182	44.3	172	48.8	162	53.9	150	59.4	139	64.7	-	-
	10	200	38.9	187	44.8	177	49.3	166	54.4	154	59.9	143	65.4	-	-
	11	205	39.3	192	45.2	181	49.8	170	54.9	158	60.5	147	66.0	-	-
	12	211	39.7	197	45.7	186	50.3	175	55.5	163	61.1	151	66.6	-	-
180	5	199	41.0	185	47.2	175	52.0	165	57.4	153	63.2	142	68.9	130	74.5
	6	204	41.4	191	47.7	180	52.5	169	57.9	157	63.8	146	69.6	134	75.2
	7	210	41.9	196	48.2	185	53.1	174	58.5	162	64.5	150	70.3	138	76.0
	8	216	42.3	202	48.7	191	53.6	179	59.1	166	65.2	154	71.1	-	-
	9	222	42.7	207	49.2	196	54.2	184	59.7	171	65.8	158	71.8	-	-
	10	228	43.2	213	49.7	201	54.7	189	60.3	176	66.5	163	72.5	-	-
	11	234	43.6	218	50.2	206	55.3	194	60.9	180	67.2	167	73.2	-	-
	12	240	44.0	224	50.6	212	55.8	199	61.5	185	67.8	171	73.9	-	-
200	5	221	46.0	207	53.0	195	58.3	183	64.3	171	70.9	158	77.3	145	83.6
	6	228	46.5	212	53.5	201	58.9	189	64.9	175	71.6	162	78.0	149	84.4
	7	234	46.9	219	54.0	207	59.5	194	65.6	180	72.3	167	78.8	154	85.2
	8	241	47.5	225	54.6	213	60.2	199	66.3	186	73.1	172	79.7	-	-
	9	247	47.9	231	55.1	218	60.8	205	67.0	191	73.8	177	80.5	-	-
	10	254	48.4	237	55.7	224	61.4	210	67.7	196	74.6	181	81.3	-	-
	11	261	48.9	243	56.2	230	62.0	216	68.3	201	75.3	186	82.1	-	-
	12	268	49.4	250	56.8	236	62.6	222	69.0	206	76.0	191	82.9	-	-

Tw= Temperatura acqua in uscita in °C

kWf = Potenza frigorifera netta(kW).

kWa = Potenza assorbita dai compressori (kW)

Le prestazioni standard si riferiscono ad un differenza di 5 °C di temperatura tra acqua entrante ed uscente dallo scambiatore a piastre, e al funzionamento dell'unità con tutti i ventilatori alla massima velocità. Si considera inoltre un fattore di sporcamento di $0.44 \times 10^{-4} \text{ m}^2 \text{ K/W}$ e l'unità posta a zero metri sul livello del mare (Pb = 1013mbar).

TECHNICAL SPECIFICATIONS AND STANDARD PERFORMANCES - IR COOLING UNIT ONLY

Technical specifications of unit AX Extra low noise unit

Model	50	60	70	80	90	100	115	130	145	160	180	200	UM
Power supply	400V - 3ph+N - 50 Hz				400V - 3ph - 50 Hz								V-f-Hz
Type of refrigerant	R410A												/
Circuits	1												n°
Cooling capacity (1) (E)	50.7	55.5	65.2	74.5	86.2	96.2	106	119	135	150	170	189	kW
Compressors power input (1)	17.6	19.9	23.1	27.6	28.6	34.1	38.3	43.7	48.0	53.9	60.4	67.7	kW
Compressor EER	2.88	2.79	2.82	2.70	3.01	2.82	2.77	2.72	2.81	2.79	2.81	2.79	-
Total power input (1)	19.4	21.7	24.9	29.4	32.2	37.7	41.9	47.3	53.4	59.3	67.6	74.9	kW
Total EER (E)	2.61	2.56	2.62	2.53	2.68	2.55	2.53	2.52	2.53	2.53	2.51	2.52	-
ESEER (E)	3.61	3.53	3.61	3.50	3.69	3.52	3.49	3.47	3.49	3.49	3.47	3.48	-
Water flow rate (1)	2.42	2.65	3.12	3.56	4.12	4.60	5.06	5.69	6.45	7.17	8.12	9.03	l/s
Water pressure drops (1) (E)	38	46	43	36	36	36	36	35	35	35	52	51	kPa
Available static head (1) (MP)	151	130	108	84	159	145	126	103	130	105	158	120	kPa

Compressor

Type	Scroll												/
Quantity	2												n°
Load steps	0-50-100												%
Oil charge CP1	3.25	3.25	3.25	3.25	3.25	4.7	4.7	6.8	6.8	6.3	6.3	6.3	l
Oil charge CP2	3.25	3.25	3.25	3.25	4.7	4.7	6.8	6.8	6.3	6.3	6.3	6.3	l

Heat Exchanger

Type	Brazen plates												/
Quantity	1												n°
Water volume	3.6	3.6	4.6	5.4	7.6	8.4	9.7	10.9	12.6	14.5	11.1	13.0	l

Fan

Type	Axial												-
Quantity	3			2			3			4			n°
Maximum rotational speed	900												rpm
Total air flow rate	19367	19367	18733	18453	27640	26733	31627	31627	41460	39880	55280	53173	m³/h
Power input	1,8			3,6			5,4			7,2			kW

Coil

Type	Aluminum fins and copper tubes												/
Quantity	1												n°
Front area	3.38			4.72			5.90			7.41			m²

Water Storage Tank (SAA accessory)

Water volume	200			400			460			l			
Safety valve setting	600												kPa
Surge chamber volume	12			24			l						
Surge chamber default pressure	150												kPa
Max. operating pressure	1000			800			kPa						

Electrical Data

Units without hydronic kit

Total maximum power input [FLA]	48.2	50.9	58.3	68.6	76.0	81.5	89.9	98.3	117	131	150	165	A
Total maximum power input [FLI]	25.5	27.7	31.1	35.5	43.6	49.2	53.9	58.6	69.4	78.2	90.8	101	kW
Total maximum starting current [MIC]	146	147	173	211	265	270	317	325	368	382	470	485	A

Units with hydronic kit MP PS STD (1 or 2 pumps)

Total maximum power input [FLA]	50.7	53.4	60.8	71.1	79.4	84.9	93.3	102	122	136	157	171	A
Total maximum power input [FLI]	26.8	29.0	32.4	36.8	45.4	51.0	55.7	60.4	72.3	81.1	94.6	105	kW
Total maximum starting current [MIC]	148	149	175	213	268	273	320	329	373	387	477	491	A

Units with hydronic kit MP AM STD and MP SS STD (1 or 2 pumps)

Total maximum power input [FLA]	51.4	54.1	61.5	71.8	80.8	86.3	94.7	103	123	137	158	173	A
Total maximum power input [FLI]	27.2	29.4	32.8	37.2	46.5	52.1	56.8	61.5	72.7	81.5	95.6	106	kW
Total maximum starting current [MIC]	149	150	176	214	269	275	322	330	373	388	479	493	A

Units with hydronic kit MP AM HP1 and MP SS HP1 (1 or 2 pumps)

Total maximum power input [FLA]	54.4	57.1	64.6	74.9	82.2	87.8	98.1	106	125	140	161	176	A
Total maximum power input [FLI]	29.2	31.4	34.8	39.2	47.3	53.0	58.7	63.4	74.2	83.0	97.3	108	kW
Total maximum starting current [MIC]	152	153	179	217	271	276	325	334	376	390	481	496	A

Data referred to standard operating condition.

(1): water temperature: in 12°C - out 7°C air temperature: in 35°C d.b.

(2): water temperature: in 40°C - out 45°C air temperature: in 7°C d.b. 87% RH

(MP): with standard hydronic kit MP AM STD and MP SS STD

(SAA): with storage tank

(E): data declared according to LCP EUROVENT certification program

TECHNICAL SPECIFICATIONS AND STANDARD PERFORMANCES - IR COOLING UNIT ONLY

Standard performances AX Extra low noise unit

Mod. 50-100

MOD.	Tw	OUTDOOR AIR TEMPERATURE (°C D.B.)													
		20		25		30		35		40		45		50	
		kWf	kWa	kWf	kWa	kWf	kWa	kWf	kWa	kWf	kWa	kWf	kWa	kWf	kWa
50	5	57.9	12.3	54.0	14.2	51.1	15.7	47.9	17.3	44.6	19.0	41.3	20.7	37.9	22.4
	6	59.5	12.5	55.5	14.3	52.5	15.8	49.3	17.4	45.8	19.2	42.5	20.9	39.0	22.6
	7	61.2	12.6	57.1	14.5	54.0	16.0	50.7	17.6	47.2	19.4	43.7	21.1	40.1	22.9
	8	62.9	12.7	58.8	14.6	55.6	16.1	52.1	17.8	48.5	19.6	44.9	21.4	-	-
	9	64.7	12.9	60.4	14.8	57.1	16.3	53.6	18.0	49.8	19.8	46.2	21.6	-	-
	10	66.4	13.0	62.0	14.9	58.6	16.5	55.0	18.1	51.2	20.0	47.4	21.8	-	-
	11	68.1	13.1	63.6	15.1	60.1	16.6	56.4	18.3	52.5	20.2	48.6	22.0	-	-
	12	69.9	13.2	65.3	15.2	61.7	16.8	57.9	18.5	53.9	20.4	49.9	22.2	-	-
60	5	63.4	14.0	59.1	16.1	55.9	17.7	52.5	19.5	48.8	21.5	45.2	23.5	41.5	25.4
	6	65.1	14.1	60.8	16.2	57.5	17.9	53.9	19.7	50.2	21.7	46.5	23.7	42.7	25.6
	7	67.0	14.2	62.5	16.4	59.1	18.0	55.5	19.9	51.6	21.9	47.8	23.9	43.9	25.9
	8	68.9	14.4	64.3	16.6	60.8	18.2	57.1	20.1	53.1	22.2	49.2	24.2	-	-
	9	70.8	14.5	66.1	16.7	62.5	18.4	58.6	20.3	54.6	22.4	50.5	24.4	-	-
	10	72.7	14.7	67.8	16.9	64.1	18.6	60.2	20.5	56.0	22.6	51.9	24.7	-	-
	11	74.5	14.8	69.6	17.1	65.8	18.8	61.7	20.7	57.4	22.8	53.2	24.9	-	-
	12	76.6	15.0	71.5	17.2	67.6	19.0	63.4	20.9	59.0	23.1	54.6	25.1	-	-
70	5	74.4	16.2	69.5	18.7	65.7	20.6	61.6	22.7	57.4	25.0	53.1	27.2	48.8	29.4
	6	76.5	16.4	71.4	18.8	67.5	20.7	63.4	22.9	58.9	25.2	54.6	27.5	50.1	29.7
	7	78.7	16.5	73.5	19.0	69.5	21.0	65.2	23.1	60.7	25.5	56.2	27.8	51.6	30.0
	8	80.9	16.7	75.6	19.2	71.4	21.2	67.0	23.4	62.4	25.8	57.8	28.1	-	-
	9	83.2	16.9	77.6	19.4	73.4	21.4	68.9	23.6	64.1	26.0	59.4	28.4	-	-
	10	85.4	17.1	79.7	19.6	75.4	21.6	70.7	23.8	65.8	26.3	60.9	28.6	-	-
	11	87.6	17.2	81.7	19.8	77.3	21.8	72.5	24.1	67.5	26.5	62.5	28.9	-	-
	12	89.9	17.4	83.9	20.0	79.4	22.0	74.5	24.3	69.3	26.8	64.2	29.2	-	-
80	5	85.0	19.4	79.4	22.3	75.1	24.5	70.4	27.1	65.5	29.8	60.7	32.5	55.8	35.2
	6	87.4	19.5	81.6	22.5	77.1	24.8	72.4	27.3	67.4	30.1	62.4	32.8	57.3	35.5
	7	89.9	19.7	84.0	22.7	79.4	25.0	74.5	27.6	69.3	30.4	64.2	33.2	59.0	35.9
	8	92.5	20.0	86.3	23.0	81.6	25.3	76.6	27.9	71.3	30.8	66.0	33.5	-	-
	9	95.0	20.2	88.7	23.2	83.9	25.6	78.7	28.2	73.2	31.1	67.8	33.9	-	-
	10	97.6	20.4	91.1	23.4	86.1	25.8	80.8	28.5	75.2	31.4	69.6	34.2	-	-
	11	100	20.6	93.4	23.7	88.3	26.1	82.9	28.7	77.1	31.7	71.4	34.5	-	-
	12	103	20.8	95.9	23.9	90.7	26.3	85.1	29.0	79.2	32.0	73.4	34.9	-	-
90	5	98.4	20.1	91.8	23.1	86.8	25.4	81.5	28.0	75.8	30.9	70.2	33.7	64.5	36.4
	6	101	20.3	94.4	23.3	89.3	25.7	83.8	28.3	77.9	31.2	72.2	34.0	66.3	36.8
	7	104	20.5	97.1	23.5	91.9	25.9	86.2	28.6	80.2	31.5	74.3	34.4	68.2	37.2
	8	107	20.7	100	23.8	94.5	26.2	88.6	28.9	82.5	31.9	76.4	34.7	-	-
	9	110	20.9	103	24.0	97.1	26.5	91.1	29.2	84.7	32.2	78.5	35.1	-	-
	10	113	21.1	105	24.3	100	26.8	93.5	29.5	87.0	32.5	80.6	35.4	-	-
	11	116	21.3	108	24.5	102	27.0	95.9	29.8	89.2	32.8	82.6	35.8	-	-
	12	119	21.5	111	24.8	105	27.3	98.5	30.1	91.6	33.1	84.9	36.1	-	-
100	5	110	23.9	102	27.5	96.9	30.3	91.0	33.4	84.6	36.9	78.4	40.2	72.0	43.4
	6	113	24.2	105	27.8	100	30.6	93.5	33.8	87.0	37.2	80.5	40.6	74.0	43.9
	7	116	24.4	108	28.1	103	30.9	96.2	34.1	89.5	37.6	82.9	41.0	76.1	44.3
	8	119	24.7	111	28.4	105	31.3	98.9	34.5	92.0	38.0	85.2	41.4	-	-
	9	123	24.9	115	28.7	108	31.6	102	34.8	94.6	38.4	87.6	41.8	-	-
	10	126	25.2	118	29.0	111	31.9	104	35.2	97.1	38.8	89.9	42.3	-	-
	11	129	25.4	121	29.2	114	32.2	107	35.5	100	39.1	92.2	42.7	-	-
	12	133	25.7	124	29.5	117	32.5	110	35.9	102	39.5	94.7	43.1	-	-

Tw= Temperatura acqua in uscita in °C

kWf = Potenza frigorifera netta(kW).

kWa = Potenza assorbita dai compressori (kW)

Le prestazioni standard si riferiscono ad un differenza di 5 °C di temperatura tra acqua entrante ed uscente dallo scambiatore a piastre, e al funzionamento dell'unità con tutti i ventilatori alla massima velocità. Si considera inoltre un fattore di sporcamento di $0.44 \times 10^{-4} \text{ m}^2 \text{ K/W}$ e l'unità posta a zero metri sul livello del mare (Pb = 1013mbar).

TECHNICAL SPECIFICATIONS AND STANDARD PERFORMANCES - IR COOLING UNIT ONLY

Mod. 115-200

MOD.	Tw	OUTDOOR AIR TEMPERATURE (°C D.B.)													
		20		25		30		35		40		45		50	
		kWf	kWa	kWf	kWa	kWf	kWa	kWf	kWa	kWf	kWa	kWf	kWa	kWf	kWa
115	5	121	26.9	113	30.9	107	34.1	100	37.6	93.2	41.4	86.4	45.1	79.3	48.8
	6	124	27.1	116	31.2	110	34.4	103	37.9	95.8	41.8	88.8	45.6	81.5	49.3
	7	128	27.4	119	31.5	113	34.7	106	38.3	98.6	42.2	91.3	46.0	83.9	49.8
	8	132	27.7	123	31.9	116	35.1	109	38.7	101	42.7	93.9	46.5	-	-
	9	135	28.0	126	32.2	119	35.5	112	39.1	104	43.1	96.5	47.0	-	-
	10	139	28.3	130	32.5	123	35.8	115	39.5	107	43.5	99.1	47.5	-	-
	11	142	28.5	133	32.8	126	36.2	118	39.9	110	44.0	102	47.9	-	-
	12	146	28.8	136	33.2	129	36.5	121	40.3	113	44.4	104	48.4	-	-
130	5	136	30.7	127	35.3	120	38.9	113	42.9	105	47.2	97.0	51.5	89.1	55.7
	6	140	30.9	130	35.6	123	39.2	116	43.3	108	47.7	100	52.0	91.5	56.2
	7	144	31.3	134	36.0	127	39.6	119	43.7	111	48.2	103	52.5	94.2	56.8
	8	148	31.6	138	36.4	130	40.1	122	44.2	114	48.7	105	53.1	-	-
	9	152	31.9	142	36.7	134	40.5	126	44.6	117	49.2	108	53.6	-	-
	10	156	32.2	145	37.1	138	40.9	129	45.1	120	49.7	111	54.2	-	-
	11	160	32.6	149	37.5	141	41.3	132	45.5	123	50.2	114	54.7	-	-
	12	164	32.9	153	37.8	145	41.7	136	46.0	127	50.7	117	55.2	-	-
145	5	154	33.7	144	38.8	136	42.7	128	47.1	119	51.9	110	56.6	101	61.2
	6	158	34.0	148	39.1	140	43.1	131	47.5	122	52.4	113	57.1	104	61.8
	7	163	34.4	152	39.5	144	43.6	135	48.0	126	52.9	116	57.7	107	62.4
	8	168	34.7	156	40.0	148	44.0	139	48.6	129	53.5	120	58.3	-	-
	9	172	35.1	161	40.4	152	44.5	143	49.0	133	54.1	123	58.9	-	-
	10	177	35.4	165	40.8	156	44.9	146	49.5	136	54.6	126	59.5	-	-
	11	181	35.8	169	41.2	160	45.4	150	50.0	140	55.1	129	60.1	-	-
	12	186	36.1	174	41.6	164	45.8	154	50.5	144	55.7	133	60.7	-	-
160	5	171	37.8	160	43.5	151	47.9	142	52.8	132	58.2	122	63.5	112	68.6
	6	176	38.1	164	43.9	155	48.4	146	53.3	136	58.8	126	64.1	115	69.3
	7	181	38.5	169	44.3	160	48.8	150	53.9	140	59.4	129	64.7	119	70.0
	8	186	39.0	174	44.8	164	49.4	154	54.4	144	60.0	133	65.4	-	-
	9	191	39.3	179	45.3	169	49.9	159	55.0	147	60.6	137	66.1	-	-
	10	196	39.7	183	45.7	173	50.4	163	55.5	151	61.2	140	66.7	-	-
	11	201	40.1	188	46.2	178	50.9	167	56.1	155	61.8	144	67.4	-	-
	12	207	40.5	193	46.6	183	51.4	171	56.6	159	62.4	148	68.1	-	-
180	5	194	42.4	181	48.8	171	53.7	161	59.2	150	65.3	139	71.2	127	77.0
	6	199	42.8	186	49.2	176	54.2	165	59.8	154	65.9	142	71.8	131	77.7
	7	205	43.2	192	49.7	181	54.8	170	60.4	158	66.6	146	72.6	135	78.5
	8	211	43.7	197	50.3	186	55.4	175	61.1	163	67.3	151	73.4	-	-
	9	217	44.1	202	50.8	191	55.9	180	61.7	167	68.0	155	74.1	-	-
	10	223	44.6	208	51.3	196	56.5	184	62.3	172	68.7	159	74.9	-	-
	11	228	45.0	213	51.8	202	57.1	189	62.9	176	69.3	163	75.6	-	-
	12	235	45.4	219	52.3	207	57.6	194	63.5	181	70.0	167	76.3	-	-
200	5	216	47.5	201	54.7	190	60.2	179	66.4	166	73.2	154	79.8	141	86.3
	6	222	47.9	207	55.2	196	60.8	184	67.0	171	73.9	158	80.5	145	87.1
	7	228	48.4	213	55.7	201	61.4	189	67.7	176	74.6	163	81.4	150	88.0
	8	235	49.0	219	56.3	207	62.1	194	68.4	181	75.4	167	82.3	-	-
	9	241	49.5	225	56.9	213	62.7	200	69.1	186	76.2	172	83.1	-	-
	10	247	50.0	231	57.5	218	63.3	205	69.8	191	77.0	177	83.9	-	-
	11	254	50.4	237	58.0	224	63.9	210	70.5	196	77.7	181	84.7	-	-
	12	261	50.9	243	58.6	230	64.6	216	71.2	201	78.5	186	85.5	-	-

Tw= Temperatura acqua in uscita in °C

kWf = Potenza frigorifera netta(kW).

kWa = Potenza assorbita dai compressori (kW)

Le prestazioni standard si riferiscono ad un differenza di 5 °C di temperatura tra acqua entrante ed uscente dallo scambiatore a piastre, e al funzionamento dell'unità con tutti i ventilatori alla massima velocità. Si considera inoltre un fattore di sporcamento di $0.44 \times 10^{-4} \text{ m}^2 \text{ K/W}$ e l'unità posta a zero metri sul livello del mare (Pb = 1013mbar).

TECHNICAL SPECIFICATIONS AND STANDARD PERFORMANCES - IR COOLING UNIT ONLY

Desuperheater unit (VD)

Standard Unit AB

Recovery heat exchanger specifications

MODEL	50	60	70	80	90	100	115	130	145	160	180	200	UM
Type of recovery exchanger	STAINLESS STEEL BRAZE PLATES												/
Quantity	1												n°
Total water content of recovery exchangers	0.6	0.6	0.6	0.6	0.8	0.8	1.3	1.3	1.3	1.3	1.8	1.8	l
Max. operating pressure on wet side	600												kPa

Unit specification

Cooling capacity VD(1)	55.6	60.9	71.6	81.8	94.6	106	116	131	149	164	187	208	kW
Compressor power input VD (1)	15.8	17.8	20.8	24.6	27.1	30.3	34.1	38.9	43.2	48.5	53.8	60.3	kW
Total power input VD (1)	17.6	19.6	22.6	26.4	30.7	33.9	37.7	42.5	48.6	53.9	61.0	67.5	kW
EER VD (1)	3.16	3.11	3.17	3.10	3.08	3.13	3.08	3.08	3.07	3.04	3.07	3.08	-
Water flow VD (1)	2.66	2.91	3.42	3.91	4.52	5.06	5.54	6.26	7.12	7.84	8.93	9.94	l/s
Water pressure drop VD (1)	45	55	52	43	43	43	43	42	42	42	63	62	kPa
Recovered heating capacity (1)	15.7	17.6	20.0	23.6	27.1	30.4	34.4	38.4	44.0	49.3	55.4	61.3	kW
Recovered water flow rate (1)	0.75	0.84	0.96	1.13	1.29	1.45	1.64	1.83	2.10	2.36	2.65	2.93	l/s
Recovered water pressure drop (1)	9	11	14	19	15	18	11	14	18	22	18	21	kPa

(1): The data refer to: Water temperature: evaporator inlet :12°C - evaporator outlet: 7°C, Outdoor air temperature 35°C.
The data refer to: Water temperature: recovery inlet :40°C - recovery outlet: 45°C.

Low noise Unit AS

Recovery heat exchanger specifications

MODEL	50	60	70	80	90	100	115	130	145	160	180	200	UM
Type of recovery exchanger	STAINLESS STEEL BRAZE PLATES												/
Quantity	1												n°
Total water content of recovery exchangers	0.6	0.6	0.6	0.6	0.8	0.8	1.3	1.3	1.3	1.3	1.8	1.8	l
Max. operating pressure on wet side	600												kPa

Unit specification

Cooling capacity VD(1)	54.0	59.1	69.4	79.4	91.7	102	113	127	145	159	181	202	kW
Compressor power input VD (1)	16.5	18.5	21.7	25.7	28.3	31.7	35.6	40.6	45.1	50.6	56.2	63.0	kW
Total power input VD (1)	18.3	20.3	23.5	27.5	31.9	35.3	39.2	44.2	50.5	56	63.4	70.2	kW
EER VD (1)	2.95	2.91	2.95	2.89	2.87	2.89	2.88	2.87	2.87	2.84	2.85	2.88	-
Water flow VD (1)	2.58	2.82	3.32	3.79	4.38	4.87	5.40	6.07	6.93	7.60	8.65	9.65	l/s
Water pressure drop VD (1)	43	52	49	41	41	40	41	40	40	40	59	58	kPa
Recovered heating capacity (1)	15.7	17.6	20.0	23.6	27.1	30.4	34.4	38.4	44.0	49.3	55.4	61.3	kW
Recovered water flow rate (1)	0.75	0.84	0.96	1.13	1.29	1.45	1.64	1.83	2.10	2.36	2.65	2.93	l/s
Recovered water pressure drop (1)	9	11	14	19	15	18	11	14	18	22	18	21	kPa

(1): The data refer to: Water temperature: evaporator inlet :12°C - evaporator outlet: 7°C, Outdoor air temperature 35°C.
The data refer to: Water temperature: recovery inlet :40°C - recovery outlet: 45°C.

Extra Low noise Unit AX

Recovery heat exchanger specifications

MODEL	50	60	70	80	90	100	115	130	145	160	180	200	UM
Type of recovery exchanger	STAINLESS STEEL BRAZE PLATES												/
Quantity	1												n°
Total water content of recovery exchangers	0.6	0.6	0.6	0.6	0.8	0.8	1.3	1.3	1.3	1.3	1.8	1.8	l
Max. operating pressure on wet side	600												kPa

Unit specification

Cooling capacity VD(1)	52.7	57.7	67.8	77.5	89.6	100	110	124	140	156	177	197	kW
Compressor power input VD (1)	16.9	19.1	22.2	26.5	27.5	32.7	36.8	42.0	46.1	51.7	58.0	65.0	kW
Total power input VD (1)	18.7	20.9	24.0	28.3	31.1	36.3	40.4	45.6	51.5	57.1	65.2	72.2	kW
EER VD (1)	2.82	2.76	2.83	2.74	2.88	2.75	2.72	2.72	2.72	2.73	2.71	2.73	-
Water flow VD (1)	2.52	2.76	3.24	3.70	4.28	4.78	5.26	5.92	6.69	7.45	8.46	9.41	l/s
Water pressure drop VD (1)	41	50	47	39	39	39	39	38	37	38	56	55	kPa
Recovered heating capacity (1)	15.7	17.6	20.0	23.6	27.1	30.4	34.4	38.4	44.0	49.3	55.4	61.3	kW
Recovered water flow rate (1)	0.75	0.84	0.96	1.13	1.29	1.45	1.64	1.83	2.10	2.36	2.65	2.93	l/s
Recovered water pressure drop (1)	9	11	14	19	15	18	11	14	18	22	18	21	kPa

(1): The data refer to: Water temperature: evaporator inlet :12°C - evaporator outlet: 7°C, Outdoor air temperature 35°C.
The data refer to: Water temperature: recovery inlet :40°C - recovery outlet: 45°C.

TECHNICAL SPECIFICATIONS AND STANDARD PERFORMANCES - IR COOLING UNIT ONLY

Recovered heating capacity Desuperheater unit (VD)

MOD.	TWR	OUTDOOR AIR TEMPERATURE (°C D.B.)				
		25	30	35	40	45
		kW _t = RECOVERED HEATING CAPACITY [KW]				
50	30	12.8	14.7	16.9	19.3	22.0
	35	12.9	14.8	17.0	19.4	22.1
	40	12.6	14.4	16.6	18.9	21.6
	45	11.9	13.7	15.7	17.9	20.5
	50	10.9	12.5	14.3	16.4	18.7
	55	9.5	10.9	12.5	14.3	16.3
	60	7.7	8.8	10.1	11.6	13.2
	65	5.5	6.4	7.3	8.4	9.5
	70	3.0	3.5	4.0	4.6	5.2
60	30	14.6	16.8	19.0	21.7	24.6
	35	14.6	16.8	19.0	21.7	24.6
	40	14.2	16.3	18.6	21.2	24.0
	45	13.5	15.5	17.6	20.1	22.8
	50	12.4	14.2	17.0	18.5	20.9
	55	10.9	12.5	15.0	16.3	18.4
	60	9.0	10.4	12.5	13.5	15.3
	65	6.8	7.9	9.4	10.2	11.6
	70	4.3	4.9	5.9	6.4	7.2
70	30	16.6	19.0	21.6	24.7	28.0
	35	16.6	19.0	21.6	24.7	28.0
	40	16.1	18.6	21.1	24.1	27.3
	45	15.3	17.6	20.0	22.8	25.9
	50	14.0	16.2	18.4	21.0	23.8
	55	12.4	14.2	16.2	18.5	20.9
	60	10.3	11.8	13.4	15.4	17.4
	65	7.8	8.9	10.2	11.6	13.1
	70	4.8	5.6	6.3	7.2	8.2
80	30	19.4	22.2	25.4	29.2	33.4
	35	19.4	22.3	25.5	29.3	33.6
	40	19.0	21.7	24.9	28.6	32.8
	45	18.0	20.6	23.6	27.1	31.1
	50	16.4	18.8	21.6	24.8	28.4
	55	14.4	16.5	18.9	21.7	24.8
	60	11.8	13.5	15.5	17.8	20.4
	65	8.6	9.9	11.3	13.0	14.9
	70	5.0	5.7	6.5	7.5	8.6
90	30	22.5	25.6	29.2	33.3	37.8
	35	22.6	25.7	29.3	33.4	38.0
	40	22.1	25.1	28.6	32.6	37.1
	45	20.9	23.8	27.1	30.9	35.1
	50	19.1	21.8	24.8	28.3	32.1
	55	16.7	19.1	21.7	24.7	28.1
	60	13.7	15.6	17.8	20.3	23.1
	65	10.1	11.5	13.1	14.9	17.0
	70	5.9	6.7	7.6	8.7	9.9
100	30	25.5	29.0	33.0	37.5	42.5
	35	25.3	28.8	32.8	37.3	42.2
	40	24.7	28.1	32.0	36.3	41.1
	45	23.5	26.7	30.4	34.5	39.1
	50	21.7	24.7	28.2	32.0	36.2
	55	19.5	22.1	25.2	28.6	32.4
	60	16.7	19.0	21.6	24.5	27.8
	65	13.4	15.2	17.3	19.6	22.2
	70	9.5	10.8	12.3	14.0	15.8
115	30	29.1	33.0	37.5	42.5	48.1
	35	28.9	32.8	37.3	42.3	47.8
	40	28.2	31.9	36.2	41.1	46.5
	45	26.7	30.3	34.4	39.0	44.1
	50	24.7	28.0	31.7	36.0	40.7
	55	21.9	24.9	28.3	32.0	36.2
	60	18.6	21.1	24.0	27.2	30.7
	65	14.6	16.6	18.8	21.4	24.2
	70	10.0	11.4	12.9	14.6	16.5
130	30	32.3	36.6	41.5	47.1	53.2
	35	32.3	36.6	41.5	47.1	53.2
	40	31.5	35.6	40.5	45.9	51.9
	45	29.8	33.8	38.4	43.5	49.2
	50	27.4	31.1	35.3	40.0	45.2
	55	24.2	27.4	31.1	35.2	39.9
	60	20.1	22.8	25.9	29.3	33.2
	65	15.2	17.3	19.6	22.2	25.1
	70	9.6	10.8	12.3	14.0	15.8
145	30	36.7	41.7	47.4	53.6	60.5
	35	36.8	41.8	47.5	53.8	60.6
	40	35.9	40.8	46.4	52.5	59.2
	45	34.1	38.7	44.0	49.8	56.2
	50	31.3	35.6	40.4	45.7	51.5
	55	27.5	31.3	35.5	40.2	45.4
	60	22.8	25.9	29.4	33.3	37.6
	65	17.1	19.5	22.1	25.0	28.2
	70	10.5	11.9	13.5	15.3	17.3
160	30	41.5	47.1	53.4	60.5	68.2
	35	41.4	47.1	53.3	60.4	68.1
	40	40.3	45.8	52.0	58.8	66.3
	45	38.3	43.5	49.3	55.8	62.9
	50	35.2	40.0	45.4	51.3	57.9
	55	31.2	35.4	40.1	45.4	51.2
	60	26.1	29.7	33.7	38.1	42.9
	65	20.1	22.8	25.9	29.3	33.0
	70	13.1	14.8	16.8	19.0	21.5
180	30	46.6	53.0	60.0	68.0	76.6
	35	46.5	52.9	59.9	67.8	76.5
	40	45.3	51.5	58.4	66.1	74.5
	45	43.0	48.9	55.4	62.7	70.7
	50	39.6	45.0	51.0	57.7	65.0
	55	35.0	39.8	45.1	51.1	57.6
	60	29.4	33.4	37.8	42.8	48.3
	65	22.6	25.7	29.1	32.9	37.1
	70	14.7	16.7	18.9	21.4	24.1
200	30	51.6	58.6	66.4	75.2	84.8
	35	51.5	58.5	66.3	75.1	84.6
	40	50.2	57.0	64.6	73.1	82.4
	45	47.6	54.1	61.3	69.4	78.2
	50	43.8	49.8	56.4	63.8	72.0
	55	38.8	44.0	49.9	56.5	63.7
	60	32.5	36.9	41.8	47.4	53.4
	65	25.0	28.4	32.2	36.4	41.1
	70	16.2	18.5	20.9	23.7	26.7

kW_{tr} = RECOVERED HEATING CAPACITY [KW]

TWR = Desuperheater outlet water temperature, Δ_{tin-out}= 5°C

TECHNICAL SPECIFICATIONS AND STANDARD PERFORMANCES - IR COOLING UNIT ONLY

Total heat recovery unit (VR)

Standard Unit AB

Recovery heat exchanger specifications

MODEL	50	60	70	80	90	100	115	130	145	160	180	200	UM
Type of recovery exchanger	STAINLESS STEEL BRAZE PLATES												/
Quantity	1												n°
Total water content of recovery exchangers	4.6	4.6	5.4	6.2	9.7	10.9	12.6	14.5	11.1	13.0	14.6	16.3	l
Max. operating pressure on wet side	600												kPa

Unit specification

Cooling capacity VR(1)	55.6	60.9	71.6	81.8	94.6	106	116	131	149	164	187	208	kW
Total power input VR (1)	15.8	17.8	20.8	24.6	27.1	30.3	34.1	38.9	43.2	48.5	53.8	60.3	kW
EER VR (1)	3.52	3.42	3.44	3.33	3.49	3.50	3.40	3.37	3.45	3.38	3.48	3.45	-
Water flow VR (1)	2.66	2.91	3.42	3.91	4.52	5.06	5.54	6.26	7.12	7.84	8.93	9.94	l/s
Water pressure drop VR (1)	45	55	52	43	43	43	43	42	42	42	63	62	kPa
Recovered heating capacity (1)	70.6	77.8	91.4	105	120	135	148	168	190	210	238	265	kW
Recovered water flow rate (1)	3.37	3.72	4.37	5.02	5.73	6.45	7.07	8.03	9.08	10.0	11.4	12.7	l/s
Recovered water pressure drop (1)	39	47	52	54	47	47	45	46	47	48	50	51	kPa

(1): The data refer to: Water temperature: evaporator inlet :12°C - evaporator outlet: 7°C, Outdoor air temperature 35°C.
The data refer to: Water temperature: recovery inlet :40°C - recovery outlet: 45°C.

Low noise Unit AS

Recovery heat exchanger specifications

MODEL	50	60	70	80	90	100	115	130	145	160	180	200	UM
Type of recovery exchanger	STAINLESS STEEL BRAZE PLATES												/
Quantity	1												n°
Total water content of recovery exchangers	4.6	4.6	5.4	6.2	9.7	10.9	12.6	14.5	11.1	13.0	14.6	16.3	l
Max. operating pressure on wet side	600												kPa

Unit specification

Cooling capacity VR(1)	55.6	60.9	71.6	81.8	94.6	106	116	131	149	164	187	208	kW
Total power input VR (1)	15.8	17.8	20.8	24.6	27.1	30.3	34.1	38.9	43.2	48.5	53.8	60.3	kW
EER VR (1)	3.52	3.42	3.44	3.33	3.49	3.50	3.40	3.37	3.45	3.38	3.48	3.45	-
Water flow VR (1)	2.66	2.91	3.42	3.91	4.52	5.06	5.54	6.26	7.12	7.84	8.93	9.94	l/s
Water pressure drop VR (1)	45	55	52	43	43	43	43	42	42	42	63	62	kPa
Recovered heating capacity (1)	70.6	77.8	91.4	105	120	135	148	168	190	210	238	265	kW
Recovered water flow rate (1)	3.37	3.72	4.37	5.02	5.73	6.45	7.07	8.03	9.08	10.0	11.4	12.7	l/s
Recovered water pressure drop (1)	39	47	52	54	47	47	45	46	47	48	50	51	kPa

(1): The data refer to: Water temperature: evaporator inlet :12°C - evaporator outlet: 7°C, Outdoor air temperature 35°C.
The data refer to: Water temperature: recovery inlet :40°C - recovery outlet: 45°C.

Extra Low noise Unit AX

Recovery heat exchanger specifications

MODEL	50	60	70	80	90	100	115	130	145	160	180	200	UM
Type of recovery exchanger	STAINLESS STEEL BRAZE PLATES												/
Quantity	1												n°
Total water content of recovery exchangers	4.6	4.6	5.4	6.2	9.7	10.9	12.6	14.5	11.1	13.0	14.6	16.3	l
Max. operating pressure on wet side	600												kPa

Unit specification

Cooling capacity VR(1)	55.6	60.9	71.6	81.8	94.6	106	116	131	149	164	187	208	kW
Total power input VR (1)	15.8	17.8	20.8	24.6	27.1	30.3	34.1	38.9	43.2	48.5	53.8	60.3	kW
EER VR (1)	3.52	3.42	3.44	3.33	3.49	3.50	3.40	3.37	3.45	3.38	3.48	3.45	-
Water flow VR (1)	2.66	2.91	3.42	3.91	4.52	5.06	5.54	6.26	7.12	7.84	8.93	9.94	l/s
Water pressure drop VR (1)	45	55	52	43	43	43	43	42	42	42	63	62	kPa
Recovered heating capacity (1)	70.6	77.8	91.4	105	120	135	148	168	190	210	238	265	kW
Recovered water flow rate (1)	3.37	3.72	4.37	5.02	5.73	6.45	7.07	8.03	9.08	10.0	11.4	12.7	l/s
Recovered water pressure drop (1)	39	47	52	54	47	47	45	46	47	48	50	51	kPa

(1): The data refer to: Water temperature: evaporator inlet :12°C - evaporator outlet: 7°C, Outdoor air temperature 35°C.
The data refer to: Water temperature: recovery inlet :40°C - recovery outlet: 45°C.

TECHNICAL SPECIFICATIONS AND STANDARD PERFORMANCES - IR COOLING UNIT ONLY

Recovered heating capacity Total heat recovery unit (VR)

MOD.	TWE	TWR - RECOVERY TEMPERATURE (°C)				
		35	40	45	50	55
		kW _t = RECOVERED HEATING CAPACITY [KW]				
50	5	71.5	69.5	67.3	65.1	63.1
	6	73.2	71.1	69.0	66.7	64.5
	7	75.1	73.0	70.6	68.4	66.0
	8	77.0	74.8	72.4	70.0	67.5
	9	78.9	76.6	74.2	71.6	69.1
	10	80.7	78.4	75.9	73.3	70.6
	11	82.6	80.3	77.6	74.9	72.1
12	84.6	82.0	79.5	76.6	73.8	
60	5	78.5	76.4	74.1	71.8	69.6
	6	80.5	78.2	75.9	73.5	71.0
	7	82.6	80.2	77.8	75.3	72.7
	8	84.7	82.3	79.8	77.1	74.5
	9	86.8	84.2	81.6	78.9	76.2
	10	88.8	86.2	83.5	80.7	77.9
	11	90.8	88.2	85.4	82.5	79.5
12	93.1	90.3	87.4	84.4	81.3	
70	5	92.2	89.7	87.1	84.3	81.6
	6	94.5	91.9	89.1	86.3	83.5
	7	96.8	94.2	91.4	88.5	85.5
	8	99.3	96.5	93.6	90.5	87.4
	9	102	98.9	95.8	92.5	89.5
	10	104	101	98.0	94.7	91.4
	11	107	104	100	96.8	93.4
12	109	106	103	99.0	95.4	
80	5	106	103	100	97.3	94.3
	6	109	106	103	99.5	96.2
	7	111	108	105	102	98.5
	8	114	111	108	104	101
	9	117	114	110	107	103
	10	120	116	113	109	105
	11	123	119	115	111	108
12	126	122	118	114	110	
90	5	122	118	115	111	107
	6	125	121	117	114	110
	7	128	124	120	116	112
	8	131	127	123	119	115
	9	134	130	126	122	118
	10	138	133	129	125	120
	11	141	137	132	128	123
12	144	140	135	130	126	
100	5	136	133	129	124	120
	6	140	136	132	127	123
	7	143	139	135	130	126
	8	147	143	138	134	129
	9	151	146	142	137	132
	10	154	150	145	140	135
	11	158	153	148	143	138
12	162	157	152	146	141	

MOD.	TWE	TWR - RECOVERY TEMPERATURE (°C)				
		35	40	45	50	55
		kW _t = RECOVERED HEATING CAPACITY [KW]				
115	5	150	146	142	137	133
	6	154	150	145	141	136
	7	158	153	149	144	139
	8	162	157	153	148	143
	9	166	161	156	151	146
	10	170	165	160	154	149
	11	174	169	163	158	152
12	178	173	167	161	156	
130	5	169	165	160	155	150
	6	174	169	164	159	154
	7	178	173	168	163	157
	8	183	178	172	167	161
	9	187	182	176	170	165
	10	192	186	180	174	168
	11	196	190	184	178	172
12	201	195	189	182	176	
145	5	192	186	181	175	170
	6	196	191	185	179	173
	7	201	196	190	184	178
	8	207	201	194	188	182
	9	212	206	199	192	186
	10	217	210	204	197	190
	11	222	215	208	201	194
12	227	220	213	206	198	
160	5	212	207	201	194	188
	6	217	211	205	199	192
	7	223	217	210	204	197
	8	229	222	216	209	202
	9	234	228	221	213	206
	10	240	233	226	218	211
	11	246	238	231	223	215
12	252	244	236	228	220	
180	5	241	234	227	220	213
	6	247	240	232	225	217
	7	253	246	238	231	223
	8	259	252	244	236	228
	9	266	258	250	241	233
	10	272	264	256	247	238
	11	278	270	261	252	243
12	285	277	268	258	249	
200	5	268	261	253	245	237
	6	274	267	259	251	242
	7	282	274	265	257	248
	8	289	280	272	263	254
	9	296	287	278	269	260
	10	303	294	285	275	265
	11	310	301	291	281	271
12	317	308	298	288	277	

TWE= Evaporator outlet water temperature °C

TWR: Recovery outlet water temperature (°C)

The standard performances refer to a 5°C temperature difference between the water entering and leaving the plate-type heat exchanger and to operation of the unit with all fans at top speed. A 0.44×10^{-4} m² K/W fouling factor has also been considered with the unit installed at zero meters above sea level (Pb = 1013mbar).

TECHNICAL SPECIFICATIONS AND STANDARD PERFORMANCES - IP HEAT PUMP UNITS

Technical specifications of unit AB Standard unit

Model	50	60	70	80	90	100	115	130	145	160	180	200	UM	
Power supply	400V - 3ph+N - 50 Hz				400V - 3ph - 50 Hz									V-f-Hz
Type of refrigerant	R410A												/	
Circuits	1												n°	
Cooling capacity (1) (E)	52.9	57.5	67.2	74.1	89.2	99.0	110	122	138	154	178	198	kW	
Compressors power input (1)	16.7	18.4	21.8	24.7	28.0	31.4	35.4	40.0	43.9	49.8	55.0	62.5	kW	
Compressor EER	3.17	3.13	3.08	3.00	3.19	3.15	3.11	3.05	3.14	3.09	3.24	3.17	-	
Total power input (1)	18.5	20.2	23.6	26.5	31.6	35.0	39.0	43.6	49.3	55.2	62.2	69.7	kW	
Total EER (E)	2.86	2.85	2.85	2.80	2.82	2.83	2.82	2.80	2.80	2.79	2.86	2.84	-	
ESEER (E)	3.95	3.93	3.93	3.86	3.90	3.90	3.89	3.86	3.86	3.85	3.95	3.92	-	
Water flow rate (1)	2.53	2.75	3.21	3.54	4.26	4.73	5.26	5.83	6.59	7.36	8.50	9.46	l/s	
Water pressure drops (1) (E)	41	49	46	35	38	38	39	37	36	37	57	56	kPa	
Available static head (1) (MP)	138	120	102	85	149	137	117	98	125	100	144	109	kPa	
Heating capacity (2) (E)	57.5	62.6	73.8	82.3	98.7	109	124	135	153	171	195	214	kW	
Compressors power input (2)	16.7	18.5	21.9	25.1	29.0	31.4	36.4	40.1	45.1	50.0	56.2	62.6	kW	
Compressor COP	3.44	3.39	3.37	3.28	3.40	3.48	3.41	3.37	3.39	3.42	3.47	3.42	-	
Total power input (2)	18.5	20.3	23.7	26.9	32.6	35.0	40.0	43.7	50.5	55.4	63.4	69.8	kW	
Total COP (E)	3.11	3.09	3.11	3.06	3.03	3.12	3.10	3.09	3.03	3.09	3.08	3.07	-	
Water flow rate (2)	2.75	2.99	3.53	3.93	4.72	5.22	5.92	6.45	7.31	8.17	9.32	10.23	l/s	
Water pressure drops (2) (E)	48	58	55	44	47	46	49	45	45	46	68	65	kPa	
Available static head (2) (MP)	117	102	84	69	121	112	92	80	101	81	120	93	kPa	

Compressor

Type	Scroll												/
Quantity	2												n°
Load steps	0-50-100												%
Oil charge CP1	3.25	3.25	3.25	3.25	3.25	4.7	4.7	6.8	6.8	6.3	6.3	6.3	l
Oil charge CP2	3.25	3.25	3.25	3.25	4.7	4.7	6.8	6.8	6.3	6.3	6.3	6.3	l

Heat Exchanger

Type	A piastre inox saldobrasate												/
Quantity	1												n°
Water volume	3.6	3.6	4.6	5.4	7.6	8.4	9.7	10.9	12.6	14.5	11.1	13.0	l

Fan

Type	Assiali												-	
Quantity	3			2				3		4			n°	
Maximum rotational speed	900												rpm	
Total air flow rate	29050	29050	28100	27680	41460	40100	47440	47440	62190	59820	82920	79760	m³/h	
Power input	1.8				3.6				5.4		7.2			kW

Coil

Type	Alette in alluminio e tubi in rame												/	
Quantity	1												n°	
Front area	3.38			4.72				5.90			7.41			m²

Water Storage Tank (SAA accessory)

Water volume	200			400				460			l		
Safety valve setting	600												kPa
Surge chamber volume	12				24								l
Surge chamber default pressure	150												kPa
Max. operating pressure	1000				800								kPa

Electrical Data

Units without hydronic kit

Total maximum power input [FLA]	48.2	50.9	58.3	68.6	76.0	81.5	89.9	98.3	117	131	150	165	A
Total maximum power input [FLI]	25.5	27.7	31.1	35.5	43.6	49.2	53.9	58.6	69.4	78.2	90.8	101	kW
Total maximum starting current [MIC]	146	147	173	211	265	270	317	325	368	382	470	485	A

Units with hydronic kit MP PS STD (1 or 2 pumps)

Total maximum power input [FLA]	50.7	53.4	60.8	71.1	79.4	84.9	93.3	102	122	136	157	171	A
Total maximum power input [FLI]	26.8	29.0	32.4	36.8	45.4	51.0	55.7	60.4	72.3	81.1	94.6	105	kW
Total maximum starting current [MIC]	148	149	175	213	268	273	320	329	373	387	477	491	A

Units with hydronic kit MP AM STD and MP SS STD (1 or 2 pumps)

Total maximum power input [FLA]	51.4	54.1	61.5	71.8	80.8	86.3	94.7	103	123	137	158	173	A
Total maximum power input [FLI]	27.2	29.4	32.8	37.2	46.5	52.1	56.8	61.5	72.7	81.5	95.6	106	kW
Total maximum starting current [MIC]	149	150	176	214	269	275	322	330	373	388	479	493	A

Units with hydronic kit MP AM HP1 and MP SS HP1 (1 or 2 pumps)

Total maximum power input [FLA]	54.4	57.1	64.6	74.9	82.2	87.8	98.1	106	125	140	161	176	A
Total maximum power input [FLI]	29.2	31.4	34.8	39.2	47.3	53.0	58.7	63.4	74.2	83.0	97.3	108	kW
Total maximum starting current [MIC]	152	153	179	217	271	276	325	334	376	390	481	496	A

Data referred to standard operating condition.

(1): water temperature: in 12°C - out 7°C air temperature: in 35°C d.b.

(2): water temperature: in 40°C - out 45°C air temperature: in 7°C d.b. 87% RH

(MP): with standard hydronic kit MP AM STD and MP SS STD

(SAA): with storage tank

(E): data declared according to LCP EUROVENT certification program

TECHNICAL SPECIFICATIONS AND STANDARD PERFORMANCES - IP HEAT PUMP UNITS

Standard performances in cooling mode AB Standard Unit

Mod. 50-100

MOD.	Tw	OUTDOOR AIR TEMPERATURE (°C D.B.)													
		20		25		30		35		40		45		50	
		kWf	kWa	kWf	kWa	kWf	kWa	kWf	kWa	kWf	kWa	kWf	kWa	kWf	kWa
50	5	60.4	11.7	56.4	13.5	53.3	14.9	50.0	16.4	46.5	18.1	43.1	19.7	39.6	21.3
	6	62.1	11.8	57.9	13.6	54.8	15.0	51.4	16.5	47.8	18.2	44.3	19.9	40.7	21.5
	7	63.9	11.9	59.6	13.7	56.4	15.1	52.9	16.7	49.2	18.4	45.6	20.1	41.9	21.7
	8	65.7	12.1	61.3	13.9	58.0	15.3	54.4	16.9	50.6	18.6	46.9	20.3	-	-
	9	67.5	12.2	63.0	14.0	59.6	15.5	55.9	17.1	52.0	18.8	48.2	20.5	-	-
	10	69.3	12.3	64.7	14.2	61.1	15.6	57.4	17.2	53.4	19.0	49.4	20.7	-	-
	11	71.0	12.4	66.3	14.3	62.7	15.8	58.8	17.4	54.8	19.2	50.7	20.9	-	-
	12	73.0	12.6	68.1	14.5	64.4	15.9	60.4	17.6	56.2	19.4	52.1	21.1	-	-
60	5	65.6	12.9	61.3	14.9	57.9	16.4	54.4	18.0	50.6	19.9	46.8	21.7	43.0	23.4
	6	67.5	13.0	63.0	15.0	59.5	16.5	55.9	18.2	52.0	20.1	48.1	21.9	44.2	23.7
	7	69.4	13.2	64.8	15.1	61.3	16.7	57.5	18.4	53.5	20.3	49.5	22.1	45.5	23.9
	8	71.4	13.3	66.6	15.3	63.0	16.9	59.1	18.6	55.0	20.5	51.0	22.4	-	-
	9	73.4	13.4	68.5	15.5	64.7	17.0	60.8	18.8	56.5	20.7	52.4	22.6	-	-
	10	75.3	13.6	70.3	15.6	66.5	17.2	62.4	19.0	58.0	20.9	53.7	22.8	-	-
	11	77.2	13.7	72.1	15.8	68.2	17.4	64.0	19.2	59.5	21.1	55.1	23.0	-	-
	12	79.3	13.8	74.0	15.9	70.0	17.5	65.7	19.3	61.1	21.3	56.6	23.3	-	-
70	5	76.7	15.3	71.6	17.6	67.7	19.4	63.5	21.4	59.1	23.6	54.8	25.7	50.3	27.8
	6	78.8	15.4	73.6	17.8	69.6	19.6	65.3	21.6	60.8	23.8	56.3	25.9	51.7	28.0
	7	81.1	15.6	75.7	17.9	71.6	19.8	67.2	21.8	62.5	24.0	57.9	26.2	53.2	28.3
	8	83.4	15.8	77.9	18.1	73.6	20.0	69.1	22.0	64.3	24.3	59.5	26.5	-	-
	9	85.7	15.9	80.0	18.3	75.7	20.2	71.0	22.3	66.1	24.5	61.2	26.8	-	-
	10	88.0	16.1	82.1	18.5	77.7	20.4	72.9	22.5	67.8	24.8	62.8	27.0	-	-
	11	90.2	16.2	84.2	18.7	79.7	20.6	74.8	22.7	69.6	25.0	64.4	27.3	-	-
	12	92.7	16.4	86.5	18.9	81.8	20.8	76.8	22.9	71.4	25.3	66.2	27.5	-	-
80	5	84.6	17.3	79.0	19.9	74.7	22.0	70.1	24.2	65.2	26.7	60.4	29.1	55.5	31.5
	6	86.9	17.5	81.1	20.1	76.7	22.2	72.0	24.4	67.0	26.9	62.0	29.4	57.0	31.8
	7	89.5	17.7	83.5	20.3	79.0	22.4	74.1	24.7	68.9	27.2	63.9	29.7	58.7	32.1
	8	92.0	17.9	85.9	20.6	81.2	22.7	76.2	25.0	70.9	27.5	65.7	30.0	-	-
	9	94.5	18.0	88.2	20.8	83.4	22.9	78.3	25.2	72.8	27.8	67.5	30.3	-	-
	10	97.0	18.2	90.6	21.0	85.6	23.1	80.4	25.5	74.8	28.1	69.3	30.6	-	-
	11	100	18.4	92.9	21.2	87.8	23.3	82.4	25.7	76.7	28.4	71.0	30.9	-	-
	12	102	18.6	95.4	21.4	90.2	23.6	84.7	26.0	78.8	28.6	73.0	31.2	-	-
90	5	102	19.6	95.0	22.6	89.9	24.9	84.3	27.5	78.5	30.3	72.7	33.0	66.8	35.7
	6	105	19.8	97.7	22.8	92.4	25.1	86.7	27.7	80.6	30.5	74.7	33.3	68.6	36.0
	7	108	20.0	101	23.0	95.1	25.4	89.2	28.0	83.0	30.9	76.9	33.6	70.6	36.4
	8	111	20.3	103	23.3	97.7	25.7	91.7	28.3	85.3	31.2	79.0	34.0	-	-
	9	114	20.5	106	23.5	100	25.9	94.3	28.6	87.7	31.5	81.2	34.4	-	-
	10	117	20.7	109	23.8	103	26.2	96.8	28.9	90.0	31.8	83.4	34.7	-	-
	11	120	20.9	112	24.0	106	26.4	99.2	29.2	92.3	32.1	85.5	35.0	-	-
	12	123	21.1	115	24.2	109	26.7	102	29.4	94.8	32.5	87.8	35.4	-	-
100	5	113	22.0	105	25.3	100	27.9	93.6	30.8	87.1	33.9	80.7	37.0	74.1	40.0
	6	116	22.2	108	25.6	103	28.2	96.2	31.1	89.5	34.3	82.9	37.3	76.1	40.4
	7	120	22.5	112	25.8	105	28.5	99.0	31.4	92.1	34.6	85.3	37.7	78.4	40.8
	8	123	22.7	115	26.1	108	28.8	102	31.7	94.7	35.0	87.7	38.1	-	-
	9	126	22.9	118	26.4	111	29.1	105	32.1	97.3	35.3	90.1	38.5	-	-
	10	130	23.2	121	26.7	114	29.4	107	32.4	100	35.7	92.5	38.9	-	-
	11	133	23.4	124	26.9	117	29.7	110	32.7	102	36.0	94.9	39.3	-	-
	12	137	23.6	127	27.2	121	29.9	113	33.0	105	36.4	97.5	39.7	-	-

Tw= Outlet water temperature in °C

kWf = refrigerating power (kW).

kWa = Power input of compressors (kW)

The standard performances refer to a 5°C temperature difference between the water entering and leaving the plate-type heat exchanger and to operation of the unit with all the fans to top speed. A $0.44 \times 10^{-4} \text{ m}^2/\text{KW}$ fouling factor has also been considered with the unit installed at zero meters above sea level (Pb = 1013mbar).

TECHNICAL SPECIFICATIONS AND STANDARD PERFORMANCES - IP HEAT PUMP UNITS

Mod. 115-200

MOD.	Tw	OUTDOOR AIR TEMPERATURE (°C D.B.)													
		20		25		30		35		40		45		50	
		kWf	kWa	kWf	kWa	kWf	kWa	kWf	kWa	kWf	kWa	kWf	kWa	kWf	kWa
115	5	126	24.8	117	28.6	111	31.5	104	34.7	96.8	38.3	89.6	41.7	82.3	45.1
	6	129	25.1	120	28.8	114	31.8	107	35.0	99.4	38.6	92.1	42.1	84.6	45.5
	7	133	25.3	124	29.1	117	32.1	110	35.4	102	39.0	94.8	42.5	87.1	46.0
	8	137	25.6	127	29.5	121	32.5	113	35.8	105	39.4	97.5	43.0	-	-
	9	140	25.9	131	29.8	124	32.8	116	36.1	108	39.8	100	43.4	-	-
	10	144	26.1	134	30.1	127	33.1	119	36.5	111	40.2	103	43.9	-	-
	11	148	26.4	138	30.3	130	33.4	122	36.9	114	40.6	105	44.3	-	-
	12	152	26.6	142	30.6	134	33.8	126	37.2	117	41.0	108	44.7	-	-
130	5	139	28.1	130	32.3	123	35.6	115	39.2	107	43.2	99.4	47.1	91.3	51.0
	6	143	28.3	134	32.6	126	35.9	119	39.6	110	43.6	102	47.6	93.8	51.4
	7	147	28.6	137	32.9	130	36.3	122	40.0	114	44.1	105	48.1	96.6	52.0
	8	151	28.9	141	33.3	134	36.7	125	40.4	117	44.6	108	48.6	-	-
	9	156	29.2	145	33.6	137	37.0	129	40.8	120	45.0	111	49.1	-	-
	10	160	29.5	149	34.0	141	37.4	132	41.3	123	45.5	114	49.6	-	-
	11	164	29.8	153	34.3	145	37.8	136	41.7	126	45.9	117	50.1	-	-
	12	168	30.1	157	34.6	149	38.2	139	42.1	130	46.4	120	50.5	-	-
145	5	158	30.8	147	35.4	139	39.0	130	43.1	121	47.5	112	51.7	103	55.9
	6	162	31.1	151	35.8	143	39.4	134	43.5	125	47.9	116	52.2	106	56.5
	7	167	31.4	156	36.1	147	39.8	138	43.9	128	48.4	119	52.8	109	57.0
	8	171	31.8	160	36.5	151	40.3	142	44.4	132	48.9	122	53.3	-	-
	9	176	32.1	164	36.9	155	40.7	146	44.8	136	49.4	126	53.9	-	-
	10	181	32.4	169	37.3	160	41.1	150	45.3	139	49.9	129	54.4	-	-
	11	185	32.7	173	37.6	164	41.5	154	45.7	143	50.4	132	54.9	-	-
	12	190	33.0	178	38.0	168	41.9	158	46.2	147	50.9	136	55.5	-	-
160	5	176	34.9	164	40.2	155	44.3	146	48.8	135	53.8	125	58.7	115	63.5
	6	181	35.3	169	40.6	159	44.7	150	49.3	139	54.3	129	59.2	118	64.0
	7	186	35.6	174	41.0	164	45.2	154	49.8	143	54.9	133	59.8	122	64.7
	8	191	36.0	178	41.4	169	45.7	158	50.4	147	55.5	136	60.5	-	-
	9	196	36.4	183	41.9	173	46.1	163	50.9	151	56.1	140	61.1	-	-
	10	202	36.7	188	42.3	178	46.6	167	51.4	155	56.6	144	61.7	-	-
	11	207	37.1	193	42.7	183	47.0	171	51.9	159	57.2	148	62.3	-	-
	12	212	37.5	198	43.1	188	47.5	176	52.4	164	57.7	152	62.9	-	-
180	5	203	38.6	190	44.4	179	48.9	168	53.9	157	59.4	145	64.8	133	70.1
	6	209	39.0	195	44.8	184	49.4	173	54.4	161	60.0	149	65.4	137	70.7
	7	215	39.4	201	45.3	190	49.9	178	55.0	166	60.6	153	66.1	141	71.5
	8	221	39.8	206	45.8	195	50.4	183	55.6	170	61.3	158	66.8	-	-
	9	227	40.2	212	46.2	200	50.9	188	56.2	175	61.9	162	67.5	-	-
	10	233	40.6	218	46.7	206	51.4	193	56.7	180	62.5	166	68.2	-	-
	11	239	41.0	223	47.2	211	52.0	198	57.3	184	63.1	171	68.8	-	-
	12	246	41.4	229	47.6	217	52.5	203	57.8	189	63.7	175	69.5	-	-
200	5	226	43.9	211	50.5	199	55.6	187	61.3	174	67.6	161	73.7	148	79.6
	6	232	44.3	217	50.9	205	56.1	192	61.9	179	68.2	166	74.3	152	80.4
	7	239	44.7	223	51.5	211	56.7	198	62.5	184	68.9	171	75.1	157	81.2
	8	246	45.2	229	52.0	217	57.3	204	63.2	189	69.6	175	75.9	-	-
	9	253	45.7	236	52.5	223	57.9	209	63.8	195	70.3	180	76.7	-	-
	10	259	46.1	242	53.1	229	58.5	215	64.5	200	71.0	185	77.5	-	-
	11	266	46.6	248	53.6	235	59.0	220	65.1	205	71.7	190	78.2	-	-
	12	273	47.0	255	54.1	241	59.6	226	65.7	210	72.4	195	79.0	-	-

Tw= Outlet water temperature in °C

kWf = refrigerating power (kW).

kWa = Power input of compressors (kW)

The standard performances refer to a 5°C temperature difference between the water entering and leaving the plate-type heat exchanger and to operation of the unit with all the fans to top speed. A $0.44 \times 10^{-4} \text{ m}^2 \text{ K/W}$ fouling factor has also been considered with the unit installed at zero meters above sea level (Pb = 1013mbar).

TECHNICAL SPECIFICATIONS AND STANDARD PERFORMANCES - IP HEAT PUMP UNITS

Technical specifications of unit AS Low noise Unit

Model	50	60	70	80	90	100	115	130	145	160	180	200	UM	
Power supply	400V - 3ph+N - 50 Hz				400V - 3ph - 50 Hz									V-f-Hz
Type of refrigerant	R410A													/
Circuits	1													n°
Cooling capacity (1) (E)	50.8	55.2	64.5	71.1	85.6	95.0	106	117	132	148	171	190	kW	
Compressors power input (1)	17.8	19.6	23.2	26.3	29.9	33.5	37.7	42.6	46.9	53.1	58.7	66.7	kW	
Compressor EER	2.85	2.82	2.78	2.70	2.86	2.84	2.81	2.75	2.81	2.79	2.91	2.85	-	
Total power input (1)	19.6	21.4	25.0	28.1	33.5	37.1	41.3	46.2	52.3	58.5	65.9	73.9	kW	
Total EER (E)	2.59	2.58	2.58	2.53	2.56	2.56	2.57	2.53	2.52	2.53	2.59	2.57	-	
ESEER (E)	3.58	3.56	3.56	3.49	3.53	3.53	3.54	3.49	3.48	3.49	3.58	3.55	-	
Water flow rate (1)	2.43	2.64	3.08	3.40	4.09	4.54	5.06	5.59	6.31	7.07	8.17	9.08	l/s	
Water pressure drops (1) (E)	38	45	42	33	35	35	36	34	33	34	52	51	kPa	
Available static head (1) (MP)	150	130	111	92	162	148	126	107	136	108	156	119	kPa	
Heating capacity (2) (E)	56.0	61.1	71.9	80.2	96.2	106	121	132	149	167	190	209	kW	
Compressors power input (2)	15.9	17.6	20.8	23.9	27.5	29.8	34.6	38.1	42.8	47.5	53.3	59.5	kW	
Compressor COP	3.52	3.47	3.46	3.36	3.50	3.56	3.50	3.46	3.48	3.52	3.56	3.51	-	
Total power input (2)	17.7	19.4	22.6	25.7	31.1	33.4	38.2	41.7	48.2	52.9	60.5	66.7	kW	
Total COP (E)	3.16	3.15	3.18	3.12	3.09	3.17	3.17	3.17	3.09	3.16	3.14	3.13	-	
Water flow rate (2)	2.68	2.92	3.44	3.83	4.60	5.06	5.78	6.31	7.12	7.98	9.08	9.99	l/s	
Water pressure drops (2) (E)	46	55	52	42	45	43	47	43	42	44	65	62	kPa	
Available static head (2) (MP)	123	107	89	72	128	119	97	84	107	85	126	98	kPa	

Compressor

Type	Scroll													/
Quantity	2													n°
Load steps	0-50-100													%
Oil charge CP1	3.25	3.25	3.25	3.25	3.25	4.7	4.7	6.8	6.8	6.3	6.3	6.3	6.3	l
Oil charge CP2	3.25	3.25	3.25	3.25	4.7	4.7	6.8	6.8	6.3	6.3	6.3	6.3	6.3	l

Heat Exchanger

Type	Brazen plates													/
Quantity	1													n°
Water volume	3.6	3.6	4.6	5.4	7.6	8.4	9.7	10.9	12.6	14.5	11.1	13.0	l	

Fan

Type	Assiali													-
Quantity	3			2				3			4			n°
Maximum rotational speed	900													rpm
Total air flow rate	24208	24208	23417	23067	34550	33417	39533	39533	51825	49850	69100	66467	m³/h	
Power input	1.8				3.6				5.4			7.2		kW

Coil

Type	Aluminum fins and copper tubes													/
Quantity	1													n°
Front area	3.38				4.72				5.90				7.41	m²

Water Storage Tank (SAA accessory)

Water volume	200				400				460				l	
Safety valve setting	600													kPa
Surge chamber volume	12						24						l	
Surge chamber default pressure	150													kPa
Max. operating pressure	1000				800									kPa

Electrical Data

Units without hydronic kit

Total maximum power input [FLA]	48.2	50.9	58.3	68.6	76.0	81.5	89.9	98.3	117	131	150	165	A
Total maximum power input [FLI]	25.5	27.7	31.1	35.5	43.6	49.2	53.9	58.6	69.4	78.2	90.8	101	kW
Total maximum starting current [MIC]	146	147	173	211	265	270	317	325	368	382	470	485	A

Units with hydronic kit MP PS STD (1 or 2 pumps)

Total maximum power input [FLA]	50.7	53.4	60.8	71.1	79.4	84.9	93.3	102	122	136	157	171	A
Total maximum power input [FLI]	26.8	29.0	32.4	36.8	45.4	51.0	55.7	60.4	72.3	81.1	94.6	105	kW
Total maximum starting current [MIC]	148	149	175	213	268	273	320	329	373	387	477	491	A

Unità con Modulo di Pompaggio MP AM STD e MP SS STD (1 o 2 pompe)

Total maximum power input [FLA]	51.4	54.1	61.5	71.8	80.8	86.3	94.7	103	123	137	158	173	A
Total maximum power input [FLI]	27.2	29.4	32.8	37.2	46.5	52.1	56.8	61.5	72.7	81.5	95.6	106	kW
Total maximum starting current [MIC]	149	150	176	214	269	275	322	330	373	388	479	493	A

Unità con Modulo di Pompaggio MP AM HP1 e MP SS HP1 (1 o 2 pompe)

Total maximum power input [FLA]	54.4	57.1	64.6	74.9	82.2	87.8	98.1	106	125	140	161	176	A
Total maximum power input [FLI]	29.2	31.4	34.8	39.2	47.3	53.0	58.7	63.4	74.2	83.0	97.3	108	kW
Total maximum starting current [MIC]	152	153	179	217	271	276	325	334	376	390	481	496	A

Data referred to standard operating condition.

- (1): water temperature: in 12°C - out 7°C air temperature: in 35°C d.b.
 (2): water temperature: in 40°C - out 45°C air temperature: in 7°C d.b. 87% RH
 (MP): with standard hydronic kit MP AM STD and MP SS STD
 (SAA): with storage tank
 (E): data declared according to LCP EUROVENT certification program

TECHNICAL SPECIFICATIONS AND STANDARD PERFORMANCES - IP HEAT PUMP UNITS

Standard performances in cooling mode AS Low noise Unit

Mod. 50-100

MOD.	Tw	OUTDOOR AIR TEMPERATURE (°C D.B.)													
		20		25		30		35		40		45		50	
		kWf	kWa	kWf	kWa	kWf	kWa	kWf	kWa	kWf	kWa	kWf	kWa	kWf	kWa
50	5	58.0	12.5	54.1	14.4	51.2	15.8	48.0	17.5	44.7	19.2	41.4	21.0	38.0	22.7
	6	59.6	12.6	55.6	14.5	52.6	16.0	49.4	17.6	45.9	19.4	42.5	21.2	39.1	22.9
	7	61.3	12.7	57.2	14.7	54.1	16.1	50.8	17.8	47.3	19.6	43.8	21.4	40.2	23.1
	8	63.1	12.9	58.9	14.8	55.7	16.3	52.2	18.0	48.6	19.8	45.0	21.6	-	-
	9	64.8	13.0	60.5	15.0	57.2	16.5	53.7	18.2	49.9	20.0	46.3	21.8	-	-
	10	66.5	13.1	62.1	15.1	58.7	16.7	55.1	18.4	51.3	20.2	47.5	22.1	-	-
	11	68.2	13.3	63.7	15.3	60.2	16.8	56.5	18.5	52.6	20.4	48.7	22.3	-	-
12	70.1	13.4	65.4	15.4	61.9	17.0	58.0	18.7	54.0	20.6	50.0	22.5	-	-	
60	5	63.0	13.8	58.8	15.8	55.6	17.4	52.2	19.2	48.6	21.2	45.0	23.1	41.3	25.0
	6	64.8	13.9	60.4	16.0	57.2	17.6	53.6	19.4	49.9	21.4	46.2	23.3	42.5	25.2
	7	66.6	14.0	62.2	16.1	58.8	17.8	55.2	19.6	51.4	21.6	47.6	23.6	43.7	25.5
	8	68.5	14.2	64.0	16.3	60.5	18.0	56.8	19.8	52.8	21.8	48.9	23.8	-	-
	9	70.4	14.3	65.7	16.5	62.2	18.2	58.3	20.0	54.3	22.1	50.3	24.1	-	-
	10	72.3	14.5	67.5	16.6	63.8	18.3	59.9	20.2	55.7	22.3	51.6	24.3	-	-
	11	74.1	14.6	69.2	16.8	65.4	18.5	61.4	20.4	57.1	22.5	52.9	24.5	-	-
12	76.1	14.7	71.1	17.0	67.2	18.7	63.1	20.6	58.7	22.7	54.3	24.8	-	-	
70	5	73.6	16.3	68.7	18.7	65.0	20.6	61.0	22.8	56.7	25.1	52.6	27.3	48.3	29.6
	6	75.7	16.4	70.6	18.9	66.8	20.8	62.7	23.0	58.3	25.3	54.0	27.6	49.6	29.8
	7	77.9	16.6	72.7	19.1	68.7	21.0	64.5	23.2	60.0	25.6	55.6	27.9	51.1	30.1
	8	80.1	16.8	74.7	19.3	70.7	21.3	66.3	23.5	61.7	25.9	57.2	28.2	-	-
	9	82.3	17.0	76.8	19.5	72.6	21.5	68.2	23.7	63.4	26.1	58.7	28.5	-	-
	10	84.5	17.1	78.8	19.7	74.6	21.7	70.0	23.9	65.1	26.4	60.3	28.8	-	-
	11	86.6	17.3	80.9	19.9	76.5	21.9	71.8	24.2	66.8	26.6	61.8	29.0	-	-
12	89.0	17.5	83.0	20.1	78.5	22.1	73.7	24.4	68.6	26.9	63.5	29.3	-	-	
80	5	81.2	18.5	75.8	21.2	71.6	23.4	67.2	25.8	62.5	28.4	57.9	31.0	53.2	33.5
	6	83.4	18.6	77.9	21.4	73.6	23.6	69.1	26.0	64.3	28.7	59.5	31.3	54.7	33.8
	7	85.8	18.8	80.1	21.7	75.8	23.9	71.1	26.3	66.2	29.0	61.3	31.6	56.3	34.2
	8	88.3	19.0	82.4	21.9	77.9	24.1	73.1	26.6	68.0	29.3	63.0	32.0	-	-
	9	90.7	19.2	84.7	22.1	80.1	24.4	75.1	26.9	69.9	29.6	64.7	32.3	-	-
	10	93.1	19.4	86.9	22.3	82.2	24.6	77.1	27.1	71.8	29.9	66.5	32.6	-	-
	11	95.5	19.6	89.1	22.5	84.3	24.8	79.1	27.4	73.6	30.2	68.2	32.9	-	-
12	98.1	19.8	91.5	22.8	86.6	25.1	81.2	27.7	75.6	30.5	70.0	33.2	-	-	
90	5	97.7	21.0	91.2	24.1	86.2	26.6	80.9	29.3	75.3	32.3	69.7	35.2	64.1	38.1
	6	100	21.2	93.7	24.4	88.6	26.8	83.2	29.6	77.4	32.6	71.7	35.6	65.8	38.5
	7	103	21.4	96.5	24.6	91.2	27.1	85.6	29.9	79.6	33.0	73.8	35.9	67.8	38.8
	8	106	21.6	99	24.9	93.8	27.4	88.0	30.2	81.9	33.3	75.9	36.3	-	-
	9	109	21.8	102	25.1	96.4	27.7	90.5	30.5	84.2	33.7	77.9	36.7	-	-
	10	112	22.1	105	25.4	99	28.0	92.8	30.8	86.4	34.0	80.0	37.1	-	-
	11	115	22.3	107	25.6	101	28.2	95.2	31.1	88.6	34.3	82.1	37.4	-	-
12	118	22.5	110	25.9	104	28.5	97.8	31.4	91.0	34.7	84.3	37.8	-	-	
100	5	108	23.5	101	27.0	95.7	29.8	89.8	32.9	83.6	36.2	77.4	39.5	71.1	42.7
	6	111	23.7	104	27.3	98.4	30.1	92.3	33.2	85.9	36.6	79.5	39.8	73.1	43.1
	7	115	24.0	107	27.6	101	30.4	95.0	33.5	88.4	36.9	81.9	40.3	75.2	43.5
	8	118	24.2	110	27.9	104	30.7	97.7	33.9	90.9	37.3	84.2	40.7	-	-
	9	121	24.5	113	28.2	107	31.0	100	34.2	93.4	37.7	86.5	41.1	-	-
	10	124	24.7	116	28.4	110	31.3	103	34.5	95.9	38.1	88.8	41.5	-	-
	11	128	25.0	119	28.7	113	31.6	106	34.9	98.3	38.5	91.1	41.9	-	-
12	131	25.2	122	29.0	116	32.0	109	35.2	101	38.8	93.5	42.3	-	-	

Tw= Outlet water temperature in °C

kWf = refrigerating power (kW).

kWa = Power input of compressors (kW)

The standard performances refer to a 5°C temperature difference between the water entering and leaving the plate-type heat exchanger and to operation of the unit with all the fans to top speed. A 0.44 x 10⁻⁴ m²/KW fouling factor has also been considered with the unit installed at zero meters above sea level (Pb = 1013mbar).

TECHNICAL SPECIFICATIONS AND STANDARD PERFORMANCES - IP HEAT PUMP UNITS

Mod. 115-200

MOD.	Tw	OUTDOOR AIR TEMPERATURE (°C D.B.)													
		20		25		30		35		40		45		50	
		kWf	kWa	kWf	kWa	kWf	kWa	kWf	kWa	kWf	kWa	kWf	kWa	kWf	kWa
115	5	121	26.5	113	30.4	107	33.5	100	37.0	93.2	40.7	86.4	44.4	79.3	48.0
	6	124	26.7	116	30.7	110	33.8	103	37.3	95.8	41.1	88.8	44.8	81.5	48.5
	7	128	27.0	119	31.0	113	34.2	106	37.7	99	41.6	91.3	45.3	83.9	49.0
	8	132	27.3	123	31.4	116	34.6	109	38.1	101	42.0	93.9	45.8	-	-
	9	135	27.5	126	31.7	119	34.9	112	38.5	104	42.4	96.5	46.3	-	-
	10	139	27.8	130	32.0	123	35.3	115	38.9	107	42.9	99	46.7	-	-
	11	142	28.1	133	32.3	126	35.6	118	39.3	110	43.3	102	47.2	-	-
12	146	28.4	136	32.6	129	36.0	121	39.6	113	43.7	104	47.6	-	-	
130	5	134	29.9	125	34.4	118	37.9	111	41.8	103	46.0	95.3	50.2	87.6	54.3
	6	137	30.2	128	34.7	121	38.2	114	42.2	106	46.5	98.0	50.7	90.0	54.8
	7	141	30.5	132	35.1	125	38.6	117	42.6	109	47.0	101	51.2	92.6	55.3
	8	145	30.8	136	35.5	128	39.1	120	43.1	112	47.5	104	51.8	-	-
	9	149	31.1	139	35.8	132	39.5	124	43.5	115	47.9	107	52.3	-	-
	10	153	31.4	143	36.2	135	39.8	127	43.9	118	48.4	109	52.8	-	-
	11	157	31.7	147	36.5	139	40.2	130	44.4	121	48.9	112	53.3	-	-
12	161	32.1	151	36.9	142	40.6	134	44.8	124	49.4	115	53.8	-	-	
145	5	151	32.9	141	37.9	133	41.7	125	46.0	116	50.7	108	55.3	99	59.8
	6	155	33.2	145	38.2	137	42.1	128	46.4	119	51.2	111	55.8	102	60.3
	7	159	33.6	149	38.6	141	42.5	132	46.9	123	51.7	114	56.4	104	60.9
	8	164	33.9	153	39.0	145	43.0	136	47.4	126	52.3	117	57.0	-	-
	9	168	34.3	157	39.4	149	43.4	139	47.9	130	52.8	120	57.6	-	-
	10	173	34.6	161	39.8	153	43.9	143	48.4	133	53.3	123	58.1	-	-
	11	177	34.9	165	40.2	156	44.3	147	48.8	137	53.8	127	58.7	-	-
12	182	35.3	170	40.6	161	44.7	151	49.3	140	54.4	130	59.3	-	-	
160	5	169	37.3	158	42.9	149	47.2	140	52.1	130	57.4	121	62.6	111	67.7
	6	174	37.6	162	43.3	153	47.7	144	52.6	134	57.9	124	63.2	114	68.3
	7	179	38.0	167	43.7	158	48.2	148	53.1	138	58.5	128	63.8	117	69.0
	8	184	38.4	172	44.2	162	48.7	152	53.7	142	59.2	131	64.5	-	-
	9	189	38.8	176	44.6	167	49.2	156	54.2	146	59.8	135	65.2	-	-
	10	194	39.2	181	45.1	171	49.7	161	54.8	149	60.4	138	65.8	-	-
	11	199	39.6	186	45.5	175	50.2	165	55.3	153	61.0	142	66.5	-	-
12	204	40.0	191	46.0	180	50.6	169	55.8	157	61.5	146	67.1	-	-	
180	5	195	41.2	182	47.4	172	52.2	162	57.6	150	63.4	139	69.2	128	74.8
	6	201	41.6	187	47.8	177	52.7	166	58.1	155	64.0	143	69.8	132	75.5
	7	206	42.0	193	48.3	182	53.2	171	58.7	159	64.7	147	70.5	135	76.3
	8	212	42.5	198	48.9	187	53.8	176	59.3	164	65.4	152	71.3	-	-
	9	218	42.9	204	49.3	193	54.4	181	59.9	168	66.1	156	72.0	-	-
	10	224	43.3	209	49.8	198	54.9	185	60.5	173	66.7	160	72.7	-	-
	11	230	43.7	214	50.3	203	55.4	190	61.1	177	67.4	164	73.5	-	-
12	236	44.2	220	50.8	208	56.0	195	61.7	182	68.0	168	74.2	-	-	
200	5	217	46.8	202	53.8	191	59.3	180	65.4	167	72.1	155	78.6	142	85.0
	6	223	47.2	208	54.4	197	59.9	185	66.0	172	72.8	159	79.3	146	85.8
	7	229	47.7	214	54.9	202	60.5	190	66.7	177	73.5	164	80.2	150	86.7
	8	236	48.2	220	55.5	208	61.2	195	67.4	182	74.3	168	81.0	-	-
	9	242	48.7	226	56.1	214	61.8	201	68.1	187	75.1	173	81.8	-	-
	10	249	49.2	232	56.6	220	62.4	206	68.8	192	75.8	178	82.7	-	-
	11	255	49.7	238	57.2	225	63.0	211	69.5	197	76.6	182	83.5	-	-
12	262	50.2	245	57.7	231	63.6	217	70.1	202	77.3	187	84.3	-	-	

Tw= Outlet water temperature in °C

kWf = refrigerating power (kW).

kWa = Power input of compressors (kW)

The standard performances refer to a 5°C temperature difference between the water entering and leaving the plate-type heat exchanger and to operation of the unit with all the fans to top speed. A 0.44 x 10⁻⁴ m² K/W fouling factor has also been considered with the unit installed at zero meters above sea level (Pb = 1013mbar).

TECHNICAL SPECIFICATIONS AND STANDARD PERFORMANCES - IP HEAT PUMP UNITS

Standard performances in heating mode AS Low noise Unit

MOD.	Tw	OUTDOOR AIR TEMPERATURE (°C D.B.)													
		-6		-2		2		6		9		12		15	
		kWt	kWa	kWt	kWa	kWt	kWa	kWt	kWa	kWt	kWa	kWt	kWa	kWt	kWa
50	30	42.8	11.3	49.0	11.4	53.6	11.5	57.0	11.6	61.1	11.7	65.4	11.9	69.9	12.0
	35	42.5	12.5	48.8	12.6	53.3	12.8	56.7	12.9	60.8	13.0	65.0	13.2	69.6	13.3
	40	42.3	13.9	48.5	14.0	53.0	14.2	56.4	14.3	60.5	14.5	64.7	14.6	69.2	14.8
	45	42.0	15.5	48.1	15.6	52.7	15.8	56.0	15.9	60.1	16.1	64.2	16.3	68.7	16.5
	50	41.7	17.2	47.8	17.3	52.3	17.6	55.6	17.7	59.6	17.9	63.8	18.1	68.2	18.3
60	30	46.7	12.5	53.5	12.6	58.5	12.8	62.2	12.9	66.7	13.0	71.3	13.1	76.3	13.3
	35	46.4	13.9	53.2	14.0	58.2	14.2	61.9	14.2	66.4	14.4	71.0	14.6	75.9	14.7
	40	46.2	15.4	52.9	15.5	57.9	15.7	61.5	15.8	66.0	16.0	70.5	16.2	75.5	16.4
	45	45.8	17.2	52.5	17.3	57.5	17.5	61.1	17.6	65.5	17.8	70.1	18.0	74.9	18.2
	50	45.5	19.1	52.2	19.2	57.1	19.5	61.1	19.6	65.1	19.8	69.6	20.0	74.4	20.2
70	30	54.9	14.8	62.9	14.9	68.8	15.1	73.2	15.2	78.5	15.4	83.9	15.5	89.8	15.7
	35	54.6	16.4	62.6	16.5	68.5	16.7	72.8	16.8	78.1	17.0	83.5	17.2	89.3	17.4
	40	54.3	18.2	62.2	18.4	68.1	18.6	72.4	18.7	77.6	18.9	83.0	19.1	88.8	19.4
	45	53.9	20.3	61.8	20.4	67.6	20.7	71.9	20.8	77.1	21.0	82.4	21.3	88.2	21.5
	50	53.6	22.5	61.4	22.7	67.1	23.0	71.4	23.1	76.6	23.4	81.9	23.7	87.6	23.9
80	30	61.2	17.0	70.2	17.1	76.8	17.4	81.6	17.5	87.6	17.7	93.6	17.9	100.1	18.1
	35	60.9	18.9	69.8	19.0	76.4	19.2	81.2	19.3	87.1	19.6	93.1	19.8	99.6	20.0
	40	60.6	21.0	69.4	21.1	75.9	21.4	80.8	21.5	86.6	21.8	92.6	22.0	99.1	22.3
	45	60.2	23.3	68.9	23.4	75.4	23.8	80.2	23.9	86.0	24.2	92.0	24.5	98.4	24.7
	50	59.7	25.9	68.5	26.1	74.9	26.4	79.6	26.6	85.4	26.9	91.3	27.2	97.7	27.5
90	30	73.5	19.6	84.2	19.7	92.1	20.0	97.9	20.1	105	20.3	112	20.5	120	20.8
	35	73.1	21.7	83.8	21.8	91.6	22.1	97.4	22.3	104	22.5	112	22.8	120	23.0
	40	72.7	24.1	83.3	24.3	91.1	24.6	96.9	24.7	104	25.0	111	25.3	119	25.6
	45	72.2	26.8	82.7	27.0	90.5	27.3	96.2	27.5	103	27.8	110	28.1	118	28.5
	50	71.7	29.8	82.1	30.0	89.8	30.4	95.5	30.6	102	30.9	110	31.3	117	31.6
100	30	80.9	21.2	92.8	21.3	101	21.6	108	21.8	116	22.0	124	22.3	132	22.5
	35	80.5	23.5	92.3	23.7	101	24.0	107	24.1	115	24.4	123	24.7	132	25.0
	40	80.1	26.1	91.8	26.3	100	26.7	107	26.8	114	27.1	122	27.4	131	27.7
	45	79.5	29.1	91.1	29.2	99.7	29.6	106	29.8	114	30.1	122	30.5	130	30.8
	50	79.0	32.3	90.5	32.5	99.0	32.9	105	33.1	113	33.5	121	33.9	129	34.3
115	30	92.4	24.6	106	24.8	116	25.1	123	25.3	132	25.6	141	25.9	151	26.1
	35	91.9	27.3	105	27.5	115	27.8	123	28.0	131	28.3	141	28.6	150	29.0
	40	91.4	30.4	105	30.5	115	31.0	122	31.1	131	31.5	140	31.9	149	32.2
	45	90.8	33.7	104	33.9	114	34.4	121	34.6	130	35.0	139	35.4	148	35.8
	50	90.1	37.5	103	37.7	113	38.2	120	38.5	129	38.9	138	39.4	147	39.8
130	30	101	27.1	116	27.3	126	27.7	134	27.8	144	28.1	154	28.5	165	28.8
	35	100	30.1	115	30.2	126	30.7	134	30.8	143	31.2	153	31.5	164	31.9
	40	99.7	33.4	114	33.6	125	34.1	133	34.3	143	34.7	152	35.1	163	35.5
	45	99.0	37.1	113	37.4	124	37.9	132	38.1	142	38.5	151	39.0	162	39.4
	50	98.3	41.3	113	41.5	123	42.1	131	42.4	141	42.8	150	43.3	161	43.8
145	30	114	30.5	130	30.7	143	31.1	152	31.3	163	31.6	174	32.0	186	32.3
	35	113	33.8	130	34.0	142	34.4	151	34.6	162	35.0	173	35.4	185	35.8
	40	113	37.5	129	37.8	141	38.3	150	38.5	161	39.0	172	39.4	184	39.8
	45	112	41.7	128	42.0	140	42.6	149	42.8	160	43.3	171	43.8	183	44.3
	50	111	46.4	127	46.7	139	47.3	148	47.6	159	48.1	170	48.7	182	49.2
160	30	128	33.8	146	34.0	160	34.5	170	34.7	182	35.1	195	35.5	209	35.9
	35	127	37.5	145	37.7	159	38.2	169	38.4	181	38.9	194	39.3	207	39.8
	40	126	41.7	145	41.9	158	42.5	168	42.7	180	43.2	193	43.7	206	44.2
	45	125	46.3	144	46.6	157	47.2	167	47.5	179	48.0	191	48.6	205	49.1
	50	124	51.5	143	51.8	156	52.5	166	52.8	178	53.4	190	54.0	203	54.6
180	30	145	37.9	166	38.2	182	38.7	193	38.9	207	39.4	222	39.8	237	40.3
	35	144	42.1	165	42.3	181	42.9	192	43.1	206	43.6	221	44.1	236	44.6
	40	144	46.8	164	47.0	180	47.7	191	48.0	205	48.5	219	49.1	235	49.6
	45	143	52.0	163	52.3	179	53.0	190	53.3	204	53.9	218	54.5	233	55.1
	50	142	57.8	162	58.1	177	58.9	189	59.3	202	59.9	216	60.6	231	61.3
200	30	160	42.4	183	42.6	200	43.2	213	43.4	228	44.0	244	44.5	261	45.0
	35	159	46.9	182	47.2	199	47.9	212	48.2	227	48.7	243	49.3	260	49.8
	40	158	52.2	181	52.5	198	53.2	210	53.5	226	54.2	241	54.8	258	55.4
	45	157	58.0	180	58.4	197	59.2	209	59.5	224	60.2	240	60.9	256	61.6
	50	156	64.5	178	64.9	195	65.8	208	66.1	223	66.9	238	67.7	255	68.4

Tw= Outlet water temperature in °C

kWt = heating output (kW).

kWa = Power input of compressors (kW)

The standard performances refer to a 5°C temperature difference between the water entering and leaving the plate-type heat exchanger, outdoor air with 87% relative humidity and to operation of the unit with all the fans to top speed. A 0.44 x 10-4 m2 K/W fouling factor has also been considered with the unit installed at zero meters above sea level (Pb = 1013mbar).

NOTE

For air temperatures of less than 7°C, the heating capacity is declared without considering the effect of the defrosting, strictly correlated with the humidity in the outdoor air.

TECHNICAL SPECIFICATIONS AND STANDARD PERFORMANCES - IP HEAT PUMP UNITS

Technical specifications of unit AX Extra low noise unit

Model	50	60	70	80	90	100	115	130	145	160	180	200	UM	
Power supply	400V - 3ph+N - 50 Hz				400V - 3ph - 50 Hz									V-f-Hz
Type of refrigerant	R410A												/	
Circuits	1												n°	
Cooling capacity (1) (E)	49.7	54.1	63.2	69.7	83.8	93.1	103	115	130	145	167	186	kW	
Compressors power input (1)	18.9	20.8	24.6	27.9	31.8	35.6	40.1	45.2	49.8	56.4	62.5	70.9	kW	
Compressor EER	2.63	2.60	2.57	2.50	2.64	2.62	2.57	2.54	2.61	2.57	2.67	2.62	-	
Total power input (1)	20.7	22.6	26.4	29.7	35.4	39.2	43.7	48.8	55.2	61.8	69.7	78.1	kW	
Total EER (E)	2.40	2.39	2.39	2.35	2.37	2.38	2.36	2.36	2.36	2.35	2.40	2.38	-	
ESEER (E)	3.31	3.30	3.30	3.24	3.27	3.28	3.25	3.25	3.25	3.24	3.31	3.29	-	
Water flow rate (1)	2.37	2.58	3.02	3.33	4.00	4.45	4.92	5.49	6.21	6.93	7.98	8.89	l/s	
Water pressure drops (1) (E)	36	43	40	31	34	33	34	32	32	33	50	49	kPa	
Available static head (1) (MP)	158	137	115	96	169	154	134	111	140	113	164	124	kPa	
Heating capacity (2) (E)	54.0	58.9	69.4	77.4	92.8	103	117	127	144	161	183	201	kW	
Compressors power input (2)	15.0	16.7	19.8	22.7	26.1	28.3	32.8	36.2	40.6	45.0	50.5	56.3	kW	
Compressor COP	3.60	3.53	3.51	3.41	3.56	3.64	3.57	3.51	3.55	3.58	3.62	3.57	-	
Total power input (2)	16.8	18.5	21.6	24.5	29.7	31.9	36.4	39.8	46.0	50.4	57.7	63.5	kW	
Total COP (E)	3.21	3.18	3.21	3.16	3.12	3.23	3.21	3.19	3.13	3.19	3.17	3.17	-	
Water flow rate (2)	2.58	2.81	3.32	3.7	4.43	4.92	5.59	6.07	6.88	7.69	8.74	9.6	l/s	
Water pressure drops (2) (E)	43	51	49	39	41	41	44	40	40	40	60	57	kPa	
Available static head (2) (MP)	133	115	95	77	138	126	104	90	114	92	137	106	kPa	

Compressor

Type	Scroll												/
Quantity	2												n°
Load steps	0-50-100												%
Oil charge CP1	3.25	3.25	3.25	3.25	3.25	4.7	4.7	6.8	6.8	6.3	6.3	6.3	l
Oil charge CP2	3.25	3.25	3.25	3.25	4.7	4.7	6.8	6.8	6.3	6.3	6.3	6.3	l

Heat Exchanger

Type	Brazen plates												/
Quantity	1												n°
Water volume	3.6	3.6	4.6	5.4	7.6	8.4	9.7	10.9	12.6	14.5	11.1	13.0	l

Fan

Type	Axial												-
Quantity	3			2			3			4			n°
Maximum rotational speed	900												rpm
Total air flow rate	19367	19367	18733	18453	27640	26733	31627	31627	41460	39880	55280	53173	m³/h
Power input	1.8			3.6			5.4			7.2			kW

Coil

Type	Aluminum fins and copper tubes												/
Quantity	1												n°
Front area	3.38			4.72			5.90			7.41			m²

Water Storage Tank (SAA accessory)

Water volume	200			400			460			l			
Safety valve setting	600						24						kPa
Surge chamber volume	12			24									l
Surge chamber default pressure	150						800						kPa
Max. operating pressure	1000			800									kPa

Electrical Data

Units without hydronic kit

Total maximum power input [FLA]	48.2	50.9	58.3	68.6	76.0	81.5	89.9	98.3	117	131	150	165	A
Total maximum power input [FLI]	25.5	27.7	31.1	35.5	43.6	49.2	53.9	58.6	69.4	78.2	90.8	101	kW
Total maximum starting current [MIC]	146	147	173	211	265	270	317	325	368	382	470	485	A

Units with hydronic kit MP PS STD (1 or 2 pumps)

Total maximum power input [FLA]	50.7	53.4	60.8	71.1	79.4	84.9	93.3	102	122	136	157	171	A
Total maximum power input [FLI]	26.8	29.0	32.4	36.8	45.4	51.0	55.7	60.4	72.3	81.1	94.6	105	kW
Total maximum starting current [MIC]	148	149	175	213	268	273	320	329	373	387	477	491	A

Unità con Modulo di Pompaggio MP AM STD e MP SS STD (1 o 2 pompe)

Total maximum power input [FLA]	51.4	54.1	61.5	71.8	80.8	86.3	94.7	103	123	137	158	173	A
Total maximum power input [FLI]	27.2	29.4	32.8	37.2	46.5	52.1	56.8	61.5	72.7	81.5	95.6	106	kW
Total maximum starting current [MIC]	149	150	176	214	269	275	322	330	373	388	479	493	A

Unità con Modulo di Pompaggio MP AM HP1 e MP SS HP1 (1 o 2 pompe)

Total maximum power input [FLA]	54.4	57.1	64.6	74.9	82.2	87.8	98.1	106	125	140	161	176	A
Total maximum power input [FLI]	29.2	31.4	34.8	39.2	47.3	53.0	58.7	63.4	74.2	83.0	97.3	108	kW
Total maximum starting current [MIC]	152	153	179	217	271	276	325	334	376	390	481	496	A

Data referred to standard operating condition.

(1): water temperature: in 12°C - out 7°C air temperature: in 35°C d.b.

(2): water temperature: in 40°C - out 45°C air temperature: in 7°C d.b. 87% RH

(MP): with standard hydronic kit MP AM STD and MP SS STD

(SAA): with storage tank

(E): data declared according to LCP EUROVENT certification program

TECHNICAL SPECIFICATIONS AND STANDARD PERFORMANCES - IP HEAT PUMP UNITS

Standard performances in cooling mode AX Extra low noise unit

Mod. 50-100

MOD.	Tw	OUTDOOR AIR TEMPERATURE (°C D.B.)													
		20		25		30		35		40		45		50	
		kWf	kWa	kWf	kWa	kWf	kWa	kWf	kWa	kWf	kWa	kWf	kWa	kWf	kWa
50	5	56.7	13.3	53.0	15.3	50.1	16.8	47.0	18.5	43.7	20.4	40.5	22.3	37.2	24.1
	6	58.3	13.4	54.4	15.4	51.5	17.0	48.3	18.7	44.9	20.6	41.6	22.5	38.2	24.3
	7	60.0	13.5	56.0	15.6	53.0	17.1	49.7	18.9	46.2	20.8	42.8	22.7	39.3	24.6
	8	61.7	13.7	57.6	15.7	54.5	17.3	51.1	19.1	47.6	21.1	44.0	23.0	-	-
	9	63.4	13.8	59.2	15.9	56.0	17.5	52.5	19.3	48.9	21.3	45.3	23.2	-	-
	10	65.1	13.9	60.7	16.0	57.4	17.7	53.9	19.5	50.2	21.5	46.5	23.4	-	-
	11	66.7	14.1	62.3	16.2	58.9	17.9	55.3	19.7	51.4	21.7	47.6	23.7	-	-
	12	68.6	14.2	64.0	16.4	60.5	18.0	56.8	19.9	52.8	21.9	48.9	23.9	-	-
60	5	61.8	14.6	57.6	16.8	54.5	18.5	51.2	20.4	47.6	22.5	44.1	24.5	40.5	26.5
	6	63.5	14.7	59.2	16.9	56.0	18.7	52.6	20.6	48.9	22.7	45.3	24.7	41.6	26.8
	7	65.3	14.9	61.0	17.1	57.6	18.9	54.1	20.8	50.3	22.9	46.6	25.0	42.8	27.0
	8	67.2	15.0	62.7	17.3	59.3	19.1	55.6	21.0	51.8	23.2	47.9	25.3	-	-
	9	69.0	15.2	64.4	17.5	60.9	19.3	57.2	21.2	53.2	23.4	49.3	25.5	-	-
	10	70.8	15.3	66.1	17.7	62.5	19.5	58.7	21.5	54.6	23.6	50.6	25.8	-	-
	11	72.7	15.5	67.8	17.8	64.1	19.6	60.2	21.7	56.0	23.9	51.9	26.0	-	-
	12	74.6	15.6	69.7	18.0	65.9	19.8	61.8	21.9	57.5	24.1	53.3	26.3	-	-
70	5	72.1	17.3	67.3	19.9	63.7	21.9	59.8	24.1	55.6	26.6	51.5	29.0	47.3	31.3
	6	74.1	17.4	69.2	20.0	65.4	22.1	61.4	24.4	57.1	26.8	52.9	29.3	48.6	31.6
	7	76.3	17.6	71.2	20.3	67.3	22.3	63.2	24.6	58.8	27.1	54.5	29.6	50.0	32.0
	8	78.5	17.8	73.2	20.5	69.3	22.6	65.0	24.9	60.5	27.4	56.0	29.9	-	-
	9	80.6	18.0	75.3	20.7	71.2	22.8	66.8	25.1	62.1	27.7	57.5	30.2	-	-
	10	82.8	18.2	77.3	20.9	73.0	23.0	68.6	25.4	63.8	28.0	59.1	30.5	-	-
	11	84.9	18.3	79.2	21.1	74.9	23.2	70.3	25.6	65.4	28.2	60.6	30.8	-	-
	12	87.2	18.5	81.4	21.3	76.9	23.5	72.2	25.9	67.2	28.5	62.2	31.1	-	-
80	5	79.6	19.6	74.3	22.5	70.2	24.8	65.9	27.4	61.3	30.2	56.8	32.9	52.2	35.5
	6	81.8	19.8	76.3	22.7	72.2	25.0	67.7	27.6	63.0	30.4	58.4	33.2	53.6	35.9
	7	84.1	20.0	78.5	23.0	74.3	25.3	69.7	27.9	64.8	30.8	60.1	33.5	55.2	36.2
	8	86.5	20.2	80.8	23.2	76.4	25.6	71.7	28.2	66.7	31.1	61.8	33.9	-	-
	9	88.9	20.4	83.0	23.5	78.5	25.8	73.6	28.5	68.5	31.4	63.5	34.2	-	-
	10	91.3	20.6	85.2	23.7	80.6	26.1	75.6	28.8	70.3	31.7	65.1	34.6	-	-
	11	93.6	20.8	87.4	23.9	82.6	26.4	77.5	29.1	72.1	32.0	66.8	34.9	-	-
	12	96.1	21.0	89.7	24.2	84.9	26.6	79.6	29.3	74.1	32.3	68.6	35.3	-	-
90	5	95.7	22.3	89.3	25.7	84.4	28.3	79.2	31.2	73.7	34.4	68.3	37.5	62.7	40.5
	6	98.3	22.5	91.8	25.9	86.8	28.6	81.4	31.5	75.8	34.7	70.2	37.8	64.4	40.9
	7	101	22.8	94.4	26.2	89.3	28.8	83.8	31.8	78.0	35.1	72.2	38.2	66.3	41.3
	8	104	23.0	97.1	26.5	91.8	29.2	86.2	32.2	80.2	35.4	74.3	38.6	-	-
	9	107	23.2	100	26.7	94.4	29.5	88.5	32.5	82.4	35.8	76.3	39.0	-	-
	10	110	23.5	102	27.0	96.9	29.7	90.9	32.8	84.6	36.1	78.3	39.4	-	-
	11	113	23.7	105	27.3	99.3	30.0	93.2	33.1	86.7	36.5	80.3	39.8	-	-
	12	116	23.9	108	27.5	102	30.3	95.7	33.4	89.1	36.9	82.5	40.2	-	-
100	5	106	25.0	99.2	28.7	93.8	31.7	88.0	34.9	81.9	38.5	75.9	42.0	69.7	45.4
	6	109	25.2	102	29.0	96.4	32.0	90.5	35.2	84.2	38.8	78.0	42.3	71.6	45.8
	7	112	25.5	105	29.3	99.2	32.3	93.1	35.6	86.6	39.2	80.2	42.8	73.7	46.3
	8	116	25.8	108	29.6	102	32.6	95.7	36.0	89.1	39.7	82.5	43.3	-	-
	9	119	26.0	111	29.9	105	33.0	98.4	36.4	91.5	40.1	84.8	43.7	-	-
	10	122	26.3	114	30.2	108	33.3	101	36.7	94.0	40.5	87.0	44.1	-	-
	11	125	26.5	117	30.5	110	33.6	104	37.1	96.4	40.9	89.2	44.6	-	-
	12	128	26.8	120	30.8	113	34.0	106	37.4	99.0	41.3	91.7	45.0	-	-

Tw= Outlet water temperature in °C

kWf = refrigerating power (kW).

kWa = Power input of compressors (kW)

The standard performances refer to a 5°C temperature difference between the water entering and leaving the plate-type heat exchanger and to operation of the unit with all the fans to top speed. A 0.44 x 10⁻⁴ m² kW fouling factor has also been considered with the unit installed at zero meters above sea level (Pb = 1013mbar).

TECHNICAL SPECIFICATIONS AND STANDARD PERFORMANCES - IP HEAT PUMP UNITS

Mod. 115-200

MOD.	Tw	OUTDOOR AIR TEMPERATURE (°C D.B.)													
		20		25		30		35		40		45		50	
		kWf	kWa	kWf	kWa	kWf	kWa	kWf	kWa	kWf	kWa	kWf	kWa	kWf	kWa
115	5	118	28.1	110	32.4	104	35.7	97.4	39.3	90.6	43.3	83.9	47.3	77.1	51.1
	6	121	28.4	113	32.7	107	36.0	100	39.7	93.1	43.8	86.2	47.7	79.2	51.6
	7	124	28.7	116	33.0	110	36.4	103	40.1	95.8	44.2	88.8	48.2	81.5	52.1
	8	128	29.0	119	33.4	113	36.8	106	40.5	98.5	44.7	91.3	48.7	-	-
	9	131	29.3	123	33.7	116	37.1	109	40.9	101	45.1	93.8	49.2	-	-
	10	135	29.6	126	34.0	119	37.5	112	41.4	104	45.6	96.3	49.7	-	-
	11	138	29.9	129	34.4	122	37.9	115	41.8	107	46.0	98.7	50.2	-	-
	12	142	30.2	133	34.7	125	38.2	118	42.2	109	46.5	101	50.7	-	-
130	5	131	31.7	123	36.5	116	40.2	109	44.3	101	48.9	93.7	53.3	86.1	57.6
	6	135	32.0	126	36.8	119	40.6	112	44.7	104	49.3	96.3	53.8	88.4	58.1
	7	139	32.3	130	37.2	123	41.0	115	45.2	107	49.8	99.1	54.3	91.0	58.7
	8	143	32.7	133	37.6	126	41.4	118	45.7	110	50.4	102	54.9	-	-
	9	147	33.0	137	38.0	129	41.9	122	46.2	113	50.9	105	55.5	-	-
	10	151	33.4	141	38.4	133	42.3	125	46.6	116	51.4	107	56.0	-	-
	11	154	33.7	144	38.8	136	42.7	128	47.1	119	51.9	110	56.6	-	-
	12	159	34.0	148	39.1	140	43.1	131	47.5	122	52.4	113	57.1	-	-
145	5	148	34.9	139	40.2	131	44.3	123	48.8	114	53.8	106	58.7	97.3	63.5
	6	152	35.3	142	40.6	135	44.7	126	49.3	118	54.3	109	59.2	100	64.0
	7	157	35.6	146	41.0	139	45.2	130	49.8	121	54.9	112	59.8	103	64.7
	8	161	36.0	151	41.4	142	45.7	134	50.4	124	55.5	115	60.5	-	-
	9	166	36.4	155	41.9	146	46.1	137	50.9	128	56.1	118	61.1	-	-
	10	170	36.7	159	42.3	150	46.6	141	51.4	131	56.6	122	61.7	-	-
	11	175	37.1	163	42.7	154	47.0	145	51.9	135	57.2	125	62.3	-	-
	12	179	37.5	167	43.1	158	47.5	149	52.4	138	57.7	128	62.9	-	-
160	5	166	39.6	154	45.5	146	50.2	137	55.3	128	61.0	118	66.5	109	71.9
	6	170	39.9	159	46.0	150	50.6	141	55.8	131	61.5	121	67.1	112	72.5
	7	175	40.4	163	46.4	155	51.2	145	56.4	135	62.2	125	67.8	115	73.3
	8	180	40.8	168	46.9	159	51.7	149	57.0	139	62.9	128	68.5	-	-
	9	185	41.2	173	47.4	163	52.2	153	57.6	143	63.5	132	69.2	-	-
	10	190	41.6	177	47.9	168	52.8	157	58.2	146	64.1	136	69.9	-	-
	11	195	42.0	182	48.4	172	53.3	161	58.7	150	64.7	139	70.6	-	-
	12	200	42.4	187	48.8	177	53.8	166	59.3	154	65.4	143	71.3	-	-
180	5	191	43.9	178	50.5	168	55.6	158	61.3	147	67.6	136	73.7	125	79.6
	6	196	44.3	183	50.9	173	56.1	162	61.9	151	68.2	140	74.3	128	80.4
	7	202	44.7	188	51.5	178	56.7	167	62.5	155	68.9	144	75.1	132	81.2
	8	207	45.2	194	52.0	183	57.3	172	63.2	160	69.6	148	75.9	-	-
	9	213	45.7	199	52.5	188	57.9	176	63.8	164	70.3	152	76.7	-	-
	10	219	46.1	204	53.1	193	58.5	181	64.5	169	71.0	156	77.5	-	-
	11	224	46.6	209	53.6	198	59.0	186	65.1	173	71.7	160	78.2	-	-
	12	230	47.0	215	54.1	203	59.6	191	65.7	178	72.4	164	79.0	-	-
200	5	212	49.7	198	57.2	187	63.1	176	69.5	164	76.6	152	83.6	139	90.3
	6	218	50.2	204	57.8	193	63.7	181	70.2	168	77.4	156	84.3	143	91.2
	7	225	50.7	210	58.4	198	64.3	186	70.9	173	78.1	160	85.2	147	92.1
	8	231	51.3	216	59.0	204	65.0	191	71.7	178	79.0	165	86.1	-	-
	9	237	51.8	221	59.6	209	65.7	197	72.4	183	79.8	169	87.0	-	-
	10	244	52.3	227	60.2	215	66.3	202	73.1	188	80.6	174	87.9	-	-
	11	250	52.8	233	60.8	220	67.0	207	73.8	193	81.4	178	88.7	-	-
	12	257	53.3	239	61.4	226	67.6	213	74.6	198	82.2	183	89.6	-	-

Tw= Outlet water temperature in °C

kWf = refrigerating power (kW).

kWa = Power input of compressors (kW)

The standard performances refer to a 5°C temperature difference between the water entering and leaving the plate-type heat exchanger and to operation of the unit with all the fans to top speed. A $0.44 \times 10^{-4} \text{ m}^2 \text{ K/W}$ fouling factor has also been considered with the unit installed at zero meters above sea level (Pb = 1013mbar).

TECHNICAL SPECIFICATIONS AND STANDARD PERFORMANCES - IP HEAT PUMP UNITS

Standard performances in heating mode AX Extra low noise unit

MOD.	Tw	OUTDOOR AIR TEMPERATURE (°C D.B.)													
		-6		-2		2		6		9		12		15	
		kWt	kWa	kWt	kWa	kWt	kWa	kWt	kWa	kWt	kWa	kWt	kWa	kWt	kWa
50	30	41.2	10.7	47.3	10.7	51.7	10.9	55.0	11.0	59.0	11.1	63.0	11.2	67.4	11.3
	35	41.0	11.8	47.0	11.9	51.4	12.1	54.7	12.1	58.7	12.3	62.7	12.4	67.1	12.6
	40	40.8	13.2	46.7	13.2	51.1	13.4	54.4	13.5	58.3	13.7	62.4	13.8	66.7	14.0
	45	40.5	14.6	46.4	14.7	50.8	14.9	54.0	15.0	57.9	15.2	61.9	15.3	66.2	15.5
	50	40.2	16.3	46.1	16.4	50.4	16.6	53.6	16.7	57.5	16.9	61.5	17.1	65.8	17.3
60	30	45.0	11.9	51.5	12.0	56.4	12.1	60.0	12.2	64.3	12.3	68.8	12.5	73.5	12.6
	35	44.7	13.2	51.3	13.3	56.1	13.4	59.7	13.5	64.0	13.7	68.4	13.8	73.2	14.0
	40	44.5	14.7	51.0	14.7	55.8	14.9	59.3	15.0	63.6	15.2	68.0	15.4	72.8	15.5
	45	44.2	16.3	50.6	16.4	55.4	16.6	58.9	16.7	63.2	16.9	67.5	17.1	72.3	17.3
	50	43.9	18.1	50.3	18.2	55.0	18.5	58.9	18.6	62.7	18.8	67.1	19.0	71.7	19.2
70	30	53.0	14.1	60.7	14.2	66.4	14.4	70.6	14.5	75.8	14.6	81.0	14.8	86.7	15.0
	35	52.7	15.6	60.4	15.7	66.1	15.9	70.3	16.0	75.4	16.2	80.6	16.4	86.2	16.6
	40	52.4	17.4	60.1	17.5	65.7	17.7	69.9	17.8	74.9	18.0	80.1	18.2	85.7	18.4
	45	52.1	19.3	59.7	19.4	65.3	19.7	69.4	19.8	74.4	20.0	79.6	20.3	85.1	20.5
	50	51.7	21.5	59.2	21.6	64.8	21.9	68.9	22.0	73.9	22.3	79.0	22.5	84.5	22.8
80	30	59.1	16.2	67.7	16.3	74.1	16.5	78.8	16.6	84.5	16.8	90.3	17.0	96.7	17.2
	35	58.8	17.9	67.4	18.0	73.7	18.3	78.4	18.4	84.1	18.6	89.9	18.8	96.2	19.0
	40	58.5	19.9	67.0	20.0	73.3	20.3	77.9	20.4	83.6	20.7	89.4	20.9	95.6	21.1
	45	58.1	22.1	66.5	22.3	72.8	22.6	77.4	22.7	83.0	23.0	88.8	23.2	94.9	23.5
	50	57.7	24.6	66.1	24.8	72.3	25.1	76.9	25.2	82.4	25.5	88.1	25.8	94.3	26.1
90	30	70.9	18.6	81.2	18.7	88.8	18.9	94.5	19.1	101	19.3	108	19.5	116	19.7
	35	70.5	20.6	80.8	20.7	88.4	21.0	94.0	21.1	101	21.4	108	21.6	115	21.9
	40	70.1	22.9	80.3	23.0	87.9	23.3	93.4	23.5	100	23.8	107	24.0	115	24.3
	45	69.6	25.4	79.8	25.6	87.3	25.9	92.8	26.1	99.5	26.4	106	26.7	114	27.0
	50	69.1	28.3	79.2	28.5	86.7	28.8	92.2	29.0	98.8	29.4	106	29.7	113	30.0
100	30	78.7	20.1	90.1	20.3	98.6	20.5	105	20.7	112	20.9	120	21.1	129	21.4
	35	78.3	22.3	89.7	22.5	98.1	22.8	104	22.9	112	23.2	120	23.4	128	23.7
	40	77.8	24.8	89.2	25.0	97.5	25.3	104	25.5	111	25.8	119	26.1	127	26.3
	45	77.3	27.6	88.6	27.8	96.8	28.1	103	28.3	110	28.6	118	29.0	126	29.3
	50	76.7	30.7	87.9	30.9	96.2	31.3	102	31.5	110	31.8	117	32.2	125	32.6
115	30	89.3	23.4	102.4	23.5	112	23.8	119	24.0	128	24.2	137	24.5	146	24.8
	35	88.9	25.9	101.9	26.0	111	26.4	118	26.5	127	26.9	136	27.2	145	27.5
	40	88.4	28.8	101.3	28.9	111	29.3	118	29.5	126	29.9	135	30.2	145	30.5
	45	87.8	32.0	100.6	32.2	110	32.6	117	32.8	125	33.2	134	33.6	144	33.9
	50	87.2	35.6	99.9	35.8	109	36.3	116	36.5	125	36.9	133	37.3	143	37.7
130	30	97.0	25.8	111	25.9	122	26.3	129	26.4	139	26.7	148	27.0	159	27.4
	35	96.5	28.6	111	28.7	121	29.1	129	29.3	138	29.6	147	30.0	158	30.3
	40	95.9	31.8	110	31.9	120	32.4	128	32.6	137	32.9	147	33.3	157	33.7
	45	95.3	35.3	109	35.5	119	36.0	127	36.2	136	36.6	146	37.0	156	37.5
	50	94.6	39.2	108	39.5	119	40.0	126	40.2	135	40.7	145	41.2	155	41.6
145	30	110	28.9	126	29.1	138	29.5	147	29.6	157	30.0	168	30.3	180	30.7
	35	109	32.0	125	32.2	137	32.7	146	32.9	156	33.2	167	33.6	179	34.0
	40	109	35.6	125	35.8	136	36.3	145	36.5	156	37.0	166	37.4	178	37.8
	45	108	39.6	124	39.8	135	40.4	144	40.6	154	41.1	165	41.5	177	42.0
	50	107	44.0	123	44.3	134	44.9	143	45.1	153	45.7	164	46.2	175	46.7
160	30	123	32.0	141	32.2	154	32.7	164	32.9	176	33.2	188	33.6	201	34.0
	35	122	35.5	140	35.7	153	36.2	163	36.4	175	36.8	187	37.3	200	37.7
	40	122	39.5	139	39.7	152	40.3	162	40.5	174	41.0	186	41.4	199	41.9
	45	121	43.9	138	44.1	151	44.7	161	45.0	173	45.5	185	46.0	197	46.6
	50	120	48.8	137	49.1	150	49.7	160	50.0	171	50.6	183	51.2	196	51.8
180	30	140	36.0	160	36.2	175	36.7	186	36.9	200	37.3	214	37.7	229	38.2
	35	139	39.8	159	40.1	174	40.6	185	40.9	199	41.3	213	41.8	227	42.3
	40	138	44.3	158	44.6	173	45.2	184	45.4	198	46.0	211	46.5	226	47.0
	45	137	49.2	157	49.5	172	50.2	183	50.5	196	51.1	210	51.7	224	52.3
	50	136	54.7	156	55.1	171	55.8	182	56.1	195	56.8	208	57.4	223	58.1
200	30	153	40.1	176	40.3	192	40.9	205	41.1	219	41.6	235	42.1	251	42.5
	35	153	44.4	175	44.7	191	45.3	204	45.6	218	46.1	233	46.6	250	47.1
	40	152	49.4	174	49.7	190	50.4	202	50.7	217	51.2	232	51.8	248	52.4
	45	151	54.9	173	55.2	189	56.0	201	56.3	216	57.0	230	57.6	247	58.3
	50	150	61.0	172	61.4	188	62.2	200	62.6	214	63.3	229	64.0	245	64.8

Tw= Outlet water temperature in °C

kWt = heating output (kW).

kWa = Power input of compressors (kW)

The standard performances refer to a 5°C temperature difference between the water entering and leaving the plate-type heat exchanger, outdoor air with 87% relative humidity and to operation of the unit with all the fans to top speed. A 0.44 x 10-4 m2 K/W fouling factor has also been considered with the unit installed at zero meters above sea level (Pb = 1013mbar).

NOTE

For air temperatures of less than 7°C, the heating capacity is declared without considering the effect of the defrosting, strictly correlated with the humidity in the outdoor air.

TECHNICAL SPECIFICATIONS AND STANDARD PERFORMANCES - IP HEAT PUMP UNITS

Desuperheater unit (VD)

Standard Unit AB

Recovery heat exchanger specifications

MODEL	50	60	70	80	90	100	115	130	145	160	180	200	UM
Type of recovery exchanger	STAINLESS STEEL BRAZE PLATES												/
Quantity	1												n°
Total water content of recovery exchangers	0.6	0.6	0.6	0.6	0.8	0.8	1.3	1.3	1.3	1.3	1.8	1.8	l
Max. operating pressure on wet side	600												kPa

Unit specification

Cooling capacity VD(1)	55.0	59.8	69.9	77.1	92.8	103	114	127	144	160	185	206	kW
Compressor power input VD (1)	16.0	17.7	20.9	23.7	26.9	30.1	34.0	38.4	42.1	47.8	52.8	60.0	kW
Total power input VD (1)	17.8	19.5	22.7	25.5	30.5	33.7	37.6	42.0	47.5	53.2	60.0	67.2	kW
EER VD (1)	3.09	3.07	3.08	3.02	3.04	3.06	3.03	3.02	3.03	3.01	3.08	3.07	-
Water flow VD (1)	2.63	2.86	3.34	3.68	4.43	4.92	5.45	6.07	6.88	7.64	8.84	9.84	l/s
Water pressure drop VD (1)	44	53	49	38	41	41	42	40	40	40	61	60	kPa
Recovered heating capacity (1)	15.2	17.0	19.4	22.9	26.2	29.2	33.2	37.1	42.4	47.5	52.4	58.1	kW
Recovered water flow rate (1)	0.73	0.81	0.93	1.10	1.25	1.39	1.58	1.77	2.03	2.27	2.50	2.78	l/s
Recovered water pressure drop (1)	8	10	13	18	14	17	10	13	17	20	16	19	kPa

(1): The data refer to: Water temperature: evaporator inlet :12°C - evaporator outlet: 7°C, Outdoor air temperature 35°C.
The data refer to: Water temperature: recovery inlet :40°C - recovery outlet: 45°C.



NOTE : THE HEATING CAPACITY RECOVERED BY THE DESUPERHEATER EXCLUSIVELY REFERS TO UNITS OPERATING IN THE COOLING MODE.

Low noise Unit AS

Recovery heat exchanger specifications

MODEL	50	60	70	80	90	100	115	130	145	160	180	200	UM
Type of recovery exchanger	STAINLESS STEEL BRAZE PLATES												/
Quantity	1												n°
Total water content of recovery exchangers	0.6	0.6	0.6	0.6	0.8	0.8	1.3	1.3	1.3	1.3	1.8	1.8	l
Max. operating pressure on wet side	600												kPa

Unit specification

Cooling capacity VD(1)	52.8	57.4	67.1	73.9	89.0	99.0	110	122	137	154	178	198	kW
Compressor power input VD (1)	17.1	18.8	22.3	25.2	28.7	32.2	36.2	40.9	45.0	51.0	56.4	64.0	kW
Total power input VD (1)	18.9	20.6	24.1	27	32.3	35.8	39.8	44.5	50.4	56.4	63.6	71.2	kW
EER VD (1)	2.79	2.79	2.78	2.74	2.76	2.77	2.76	2.74	2.72	2.73	2.80	2.78	-
Water flow VD (1)	2.52	2.74	3.21	3.53	4.25	4.73	5.26	5.83	6.55	7.36	8.50	9.46	l/s
Water pressure drop VD (1)	41	49	46	35	38	38	39	37	36	37	57	56	kPa
Recovered heating capacity (1)	15.2	17.0	19.4	22.9	26.2	29.2	33.2	37.1	42.4	47.5	52.4	58.1	kW
Recovered water flow rate (1)	0.73	0.81	0.93	1.10	1.25	1.39	1.58	1.77	2.03	2.27	2.50	2.78	l/s
Recovered water pressure drop (1)	8	10	13	18	14	17	10	13	17	20	16	19	kPa

(1): The data refer to: Water temperature: evaporator inlet :12°C - evaporator outlet: 7°C, Outdoor air temperature 35°C.
The data refer to: Water temperature: recovery inlet :40°C - recovery outlet: 45°C.



NOTE : THE HEATING CAPACITY RECOVERED BY THE DESUPERHEATER EXCLUSIVELY REFERS TO UNITS OPERATING IN THE COOLING MODE.

Extra Low noise Unit AX

Recovery heat exchanger specifications

MODEL	50	60	70	80	90	100	115	130	145	160	180	200	UM
Type of recovery exchanger	STAINLESS STEEL BRAZE PLATES												/
Quantity	1												n°
Total water content of recovery exchangers	0.6	0.6	0.6	0.6	0.8	0.8	1.3	1.3	1.3	1.3	1.8	1.8	l
Max. operating pressure on wet side	600												kPa

Unit specification

Cooling capacity VD(1)	51.7	56.3	65.7	72.5	87.2	97.0	107	120	135	151	174	193	kW
Compressor power input VD (1)	18.1	20.0	23.6	26.8	30.5	34.2	38.5	43.4	47.8	54.1	60.0	68.1	kW
Total power input VD (1)	19.9	21.8	25.4	28.6	34.1	37.8	42.1	47	53.2	59.5	67.2	75.3	kW
EER VD (1)	2.60	2.58	2.59	2.53	2.56	2.57	2.54	2.55	2.54	2.54	2.59	2.56	-
Water flow VD (1)	2.47	2.69	3.14	3.46	4.17	4.63	5.11	5.73	6.45	7.21	8.31	9.22	l/s
Water pressure drop VD (1)	39	47	44	34	37	36	36	35	35	36	54	53	kPa
Recovered heating capacity (1)	15.2	17.0	19.4	22.9	26.2	29.2	33.2	37.1	42.4	47.5	52.4	58.1	kW
Recovered water flow rate (1)	0.73	0.81	0.93	1.10	1.25	1.39	1.58	1.77	2.03	2.27	2.50	2.78	l/s
Recovered water pressure drop (1)	8	10	13	18	14	17	10	13	17	20	16	19	kPa

(1): The data refer to: Water temperature: evaporator inlet :12°C - evaporator outlet: 7°C, Outdoor air temperature 35°C.
The data refer to: Water temperature: recovery inlet :40°C - recovery outlet: 45°C.



NOTE : THE HEATING CAPACITY RECOVERED BY THE DESUPERHEATER EXCLUSIVELY REFERS TO UNITS OPERATING IN THE COOLING MODE.

TECHNICAL SPECIFICATIONS AND STANDARD PERFORMANCES - IP HEAT PUMP UNITS

Recovered heating capacity Desuperheater unit (VD)

MOD.	TWR	OUTDOOR AIR TEMPERATURE (°C D.B.)				
		25	30	35	40	45
		kW _{tr} = RECOVERED HEATING CAPACITY [KW]				
50	30	12.4	14.2	16.3	18.6	21.2
	35	12.4	14.2	16.4	18.7	21.3
	40	12.2	13.9	16.0	18.3	20.8
	45	11.5	13.2	15.2	17.4	19.8
	50	10.6	12.1	13.9	15.9	18.1
	55	9.3	10.6	12.2	14.0	15.9
	60	7.6	8.8	10.1	11.5	13.1
	65	5.7	6.5	7.5	8.5	9.7
	70	3.3	3.8	4.4	5.0	5.7
60	30	13.9	15.9	18.2	20.8	23.6
	35	14.0	16.0	18.3	20.9	23.8
	40	13.7	15.7	17.9	20.4	23.2
	45	13.0	14.9	17.0	19.4	22.1
	50	11.9	13.7	16.4	17.8	20.2
	55	10.4	12.0	14.4	15.6	17.7
	60	8.6	9.9	11.9	12.9	14.6
	65	6.4	7.3	8.8	9.5	10.8
	70	3.8	4.3	5.2	5.6	6.4
70	30	15.9	18.2	20.8	23.7	27.0
	35	15.9	18.3	20.9	23.9	27.1
	40	15.6	17.9	20.4	23.3	26.5
	45	14.8	17.0	19.4	22.2	25.2
	50	13.6	15.6	17.8	20.3	23.1
	55	11.9	13.7	15.6	17.8	20.3
	60	9.8	11.3	12.9	14.7	16.7
	65	7.3	8.3	9.5	10.9	12.4
	70	4.3	4.9	5.6	6.4	7.3
80	30	18.7	21.5	24.6	28.2	32.0
	35	18.8	21.6	24.7	28.3	32.2
	40	18.3	21.1	24.2	27.6	31.4
	45	17.4	20.0	22.9	26.2	29.8
	50	15.9	18.3	21.0	24.0	27.3
	55	13.9	16.0	18.4	21.0	23.9
	60	11.4	13.2	15.1	17.2	19.6
	65	8.4	9.7	11.1	12.7	14.5
	70	4.9	5.7	6.5	7.4	8.4
90	30	21.7	24.8	28.2	32.3	36.7
	35	21.8	24.9	28.3	32.4	36.8
	40	21.2	24.3	27.6	31.6	36.0
	45	20.1	23.0	26.2	30.0	34.1
	50	18.4	21.1	24.0	27.4	31.2
	55	16.1	18.5	21.0	24.0	27.3
	60	13.2	15.2	17.2	19.7	22.4
	65	9.8	11.2	12.7	14.5	16.5
	70	5.7	6.5	7.4	8.5	9.6
100	30	24.4	27.8	31.5	35.8	40.5
	35	24.5	27.9	31.6	35.9	40.6
	40	23.9	27.2	30.8	35.0	39.6
	45	22.6	25.7	29.2	33.2	37.5
	50	20.7	23.5	26.7	30.3	34.3
	55	18.1	20.6	23.3	26.5	30.0
	60	14.8	16.8	19.1	21.7	24.5
	65	10.8	12.3	14.0	15.9	18.0
	70	6.2	7.0	8.0	9.1	10.3
115	30	27.8	31.6	35.9	40.6	45.8
	35	27.8	31.6	35.9	40.6	45.8
	40	27.1	30.8	35.0	39.6	44.7
	45	25.7	29.3	33.2	37.6	42.5
	50	23.7	26.9	30.5	34.6	39.1
	55	20.9	23.8	27.0	30.6	34.5
	60	17.5	19.9	22.6	25.6	28.9
	65	13.4	15.2	17.3	19.6	22.1
	70	8.6	9.8	11.1	12.6	14.2
130	30	31.2	35.3	40.1	45.4	51.4
	35	31.2	35.3	40.1	45.4	51.4
	40	30.4	34.5	39.1	44.3	50.1
	45	28.9	32.7	37.1	42.0	47.5
	50	26.5	30.0	34.1	38.6	43.7
	55	23.4	26.5	30.1	34.1	38.5
	60	19.5	22.1	25.1	28.4	32.1
	65	14.8	16.8	19.1	21.6	24.4
	70	9.4	10.6	12.0	13.6	15.4
145	30	35.7	40.6	46.0	52.1	58.8
	35	35.7	40.5	45.9	52.0	58.7
	40	34.7	39.5	44.7	50.6	57.2
	45	33.0	37.4	42.4	48.1	54.3
	50	30.3	34.5	39.0	44.2	49.9
	55	26.9	30.5	34.6	39.2	44.2
	60	22.5	25.6	29.0	32.9	37.1
	65	17.4	19.7	22.3	25.3	28.6
	70	11.3	12.9	14.6	16.5	18.7
160	30	39.8	45.2	51.2	58.0	65.5
	35	39.9	45.3	51.4	58.2	65.7
	40	39.0	44.3	50.1	56.8	64.2
	45	36.9	41.9	47.5	53.8	60.8
	50	33.8	38.3	43.4	49.2	55.6
	55	29.5	33.5	38.0	43.0	48.6
	60	24.2	27.4	31.1	35.2	39.7
	65	17.7	20.1	22.8	25.8	29.1
	70	10.1	11.5	13.0	14.8	16.7
180	30	43.9	49.8	56.5	64.0	72.2
	35	44.1	50.0	56.7	64.2	72.5
	40	43.0	48.8	55.3	62.7	70.8
	45	40.7	46.3	52.4	59.4	67.0
	50	37.3	42.3	47.9	54.3	61.3
	55	32.6	37.0	41.9	47.5	53.6
	60	26.6	30.3	34.3	38.8	43.8
	65	19.5	22.2	25.1	28.5	32.1
	70	11.2	12.7	14.4	16.3	18.4
200	30	48.7	55.3	62.6	70.9	80.1
	35	48.8	55.5	62.8	71.2	80.4
	40	47.7	54.1	61.3	69.5	78.5
	45	45.2	51.3	58.1	65.8	74.3
	50	41.3	46.9	53.1	60.2	68.0
	55	36.1	41.0	46.4	52.6	59.4
	60	29.5	33.5	38.0	43.1	48.6
	65	21.6	24.6	27.8	31.5	35.6
	70	12.4	14.1	15.9	18.1	20.4

kW_{tr} = RECOVERED HEATING CAPACITY [KW]
TWR = Desuperheater outlet water temperature, Δ_{tin-out}= 5°C

CORRECTION FACTOR FOR THE USE OF GLYCOL

Correction factor for the use of glycol IN HEATING MODE

Correction factor for the use of ethylene glycol with water produced between 30+55°C.

Percentage Of glycol in mass / volume	0 / 0	10 / 8.9	20 / 18.1	30 / 27.7	40 / 37.5
Freezing point [°C]	0	-3.2	-8	-14	-22
Heating capacity CCPF Power input CCPA	1.000	0.995	0.985	0.975	0.970
Compressor power input CCPA	1.000	1.010	1.015	1.020	1.030
Water flow rate CCQA	1.000	1.038	1.062	1.091	1.127
Water pressure drop CCDP	1.000	1.026	1.051	1.077	1.103

Correction factor for the use of Propylene Glycol with water produced between 30+55°C.

Percentage Of glycol in mass / volume	0 / 0	10 / 9.6	20 / 19.4	30 / 29.4	40 / 39.6
Freezing point [°C]	0	-3.3	-7	-13	-21
Heating capacity CCPF Power input CCPA	1.000	0.990	0.975	0.965	0.955
Compressor power input CCPA	1.000	1.010	1.020	1.030	1.040
Water flow rate CCQA	1.000	1.018	1.032	1.053	1.082
Water pressure drop CCDP	1.000	1.026	1.051	1.077	1.103

Correction factor for the use of glycol IN COOLING MODE

Correction factor for the use of ethylene glycol with water produced between 5+20°C.

Percentage Of glycol in mass / volume	0 / 0	10 / 8.9	20 / 18.1	30 / 27.7	40 / 37.5
Freezing point [°C]	0	-3.2	-8	-14	-22
Cooling capacity CCPF Power input CCPA	1.00	0.99	0.98	0.97	0.95
Compressor power input CCPA	1.00	1.00	0.99	0.99	0.98
Water flow rate CCQA	1.00	1.04	1.08	1.12	1.16
Water pressure drop CCDP	1.00	1.08	1.16	1.25	1.35

Correction factor for the use of Propylene Glycol with water produced between 5+20°C.

Percentage Of glycol in mass / volume	0 / 0	10 / 9.6	20 / 19.4	30 / 29.4	40 / 39.6
Freezing point [°C]	0	-3.3	-7	-13	-21
Cooling capacity CCPF Power input CCPA	1.00	0.98	0.96	0.94	0.92
Compressor power input CCPA	1.00	0.99	0.98	0.95	0.93
Water flow rate CCQA	1.00	1.01	1.03	1.06	1.09
Water pressure drop CCDP	1.00	1.05	1.11	1.22	1,38

GENERAL SPECIFICATIONS - BRINE UNIT BR - BP

Specific data for Brine Unit (BR-BP)

Correction factors to apply to the basic version data

	ETHYLENE GLYCOL										PROPYLENE GLYCOL									
Percentage Of glycol in mass / volume	10 / 8.9																			
freezing point [°C]	-3.2																			
Produced water temperature	4	2	0	-2	-4	-6	-8	-10	-12	4	2	0	-2	-4	-6	-8	-10	-12		
Cooling capacity c.f.	0.926	0.869	0.812	-	-	-	-	-	-	0.890	0.819	0.751	-	-	-	-	-	-		
Compressor power input c.f.	0.974	0.964	0.954	-	-	-	-	-	-	0.974	0.964	0.954	-	-	-	-	-	-		
Water flow rate c.f.	0.943	0.885	0.828	-	-	-	-	-	-	0.943	0.885	0.828	-	-	-	-	-	-		
Water pressure drop c.f.	1.040	1.045	1.050	-	-	-	-	-	-	1.040	1.045	1.050	-	-	-	-	-	-		
Percentage Of glycol in mass / volume	20 / 18.1																			
freezing point [°C]	-8																			
Produced water temperature	4	2	0	-2	-4	-6	-8	-10	-12	4	2	0	-2	-4	-6	-8	-10	-12		
Cooling capacity c.f.	0.912	0.855	0.798	0.738	0.683	-	-	-	-	0.874	0.807	0.740	0.690	0.641	-	-	-	-		
Compressor power input c.f.	0.967	0.957	0.947	0.927	0.897	-	-	-	-	0.945	0.935	0.925	0.900	0.875	-	-	-	-		
Water flow rate c.f.	0.955	0.895	0.836	0.773	0.715	-	-	-	-	0.915	0.845	0.774	0.723	0.671	-	-	-	-		
Water pressure drop c.f.	1.090	1.095	1.100	1.110	1.120	-	-	-	-	1.110	1.115	1.120	1.130	1.140	-	-	-	-		
Percentage Of glycol in mass / volume	30 / 27.7																			
freezing point [°C]	-14																			
Produced water temperature	4	2	0	-2	-4	-6	-8	-10	-12	4	2	0	-2	-4	-6	-8	-10	-12		
Cooling capacity c.f.	0.899	0.842	0.785	0.725	0.670	0.613	0.562	-	-	0.869	0.799	0.729	0.680	0.630	0.583	0.536	-	-		
Compressor power input c.f.	0.960	0.950	0.940	0.920	0.890	0.870	0.840	-	-	0.935	0.923	0.910	0.888	0.865	0.838	0.810	-	-		
Water flow rate c.f.	0.967	0.905	0.844	0.780	0.720	0.659	0.604	-	-	0.934	0.859	0.784	0.731	0.678	0.627	0.576	-	-		
Water pressure drop c.f.	1.140	1.145	1.150	1.155	1.160	1.175	1.190	-	-	1.160	1.175	1.190	1.200	1.210	1.255	1.300	-	-		
Percentage Of glycol in mass / volume	40 / 37.5																			
freezing point [°C]	-22																			
Produced water temperature	4	2	0	-2	-4	-6	-8	-10	-12	4	2	0	-2	-4	-6	-8	-10	-12		
Cooling capacity c.f.	0.884	0.827	0.770	0.710	0.655	0.598	0.547	0.490	0.437	0.848	0.784	0.719	0.670	0.620	0.570	0.520	0.478	0.438		
Compressor power input c.f.	0.880	0.870	0.860	0.840	0.810	0.790	0.760	0.724	0.686	0.865	0.855	0.845	0.820	0.795	0.773	0.750	0.714	0.680		
Water flow rate c.f.	1.150	1.151	1.153	1.154	1.155	1.157	1.158	1.159	1.161	1.116	1.114	1.112	1.110	1.108	1.107	1.105	1.103	1.101		
Water pressure drop c.f.	1.190	1.195	1.200	1.210	1.220	1.235	1.250	1.269	1.290	1.230	1.275	1.320	1.375	1.430	1.500	1.570	1.642	1.724		

A calculation example showing how the table is used is given below.

Consider unit **IR 160.2** in the Basic Version with air temperature: in 35°C d.b. and water temperature out 7°C:

- Cooling capacity of the Basic Version unit (VB): $Pf_{VB} = 158 \text{ kW}$
- Power input of the Compressors in the Basic Version unit (VB): $Pass_{CP,VB} = 53.2 \text{ kW}$
- Water Flow Rate of the Basic Version unit (VB): $Q_{VB} = 7.55 \text{ l/s}$
- Water pressure drop of the Basic Version unit (VB): $\Delta p_{VB} = 39 \text{ kPa}$
- **with 30% brine and -2°C temperature of the water produced**

The corresponding values for the Brine Unit are:

- Cooling capacity $Pf_{BR/BP} = Pf_{VB} \times (0.725) = 115 \text{ kW}$
- Compressor power input $Pass_{CP,BR/BP} = Pass_{CP,VB} \times (0.92) = 48.9 \text{ kW}$
- Water flow rate $Q_{BR/BP} = Q_{VB} \times (0.78) = 5.89 \text{ l/s}$
- Water pressure drop $\Delta p_{BR/BP} = \Delta p_{VB} \times (1.155) = 32 \text{ kPa}$

If you need to calculate the performances of the unit with outdoor air temp. different than 35°C, you have to use the values for Pf_{VB} and $Pass_{CP,VB}$ reported on the tables standard performances for the requisited air temp. and with water leaving temp=7°C.

With Pf_{VB} calculate Q_{VB} and using the graph water pressure drop Basic Version you have Δp_{VB} . Then apply the corrective coefficients indicated on the tables for BR-BP.

In case of other type of antifreezing fluid please contact our sales office.

NOISE LEVELS

The noise levels refer to units operating in the nominal conditions (water temperature: inlet: 12°C - outlet: 7°C, Outdoor air temperature 35°C), due to a change of external air temperature noise levels may change to ensure proper functioning of the unit within operating range.

The acoustic pressure levels are calculated 1/ 5 / 10 meters away from the outer surface of the unit operating in the free field and resting on a reflecting surface (directional factor of 2).

SWL = Sound power levels, with reference to 1×10^{-12} W.

The **Total** sound power level in **dB(A)** measured in compliance with **ISO 9614** standards, is certified according to the **Eurovent** certification program and it is the only mandatory value (the values of octave band in the table are indicative).

Eurovent certification (**E**) exclusively refers to the **Total** Sound Power in **dB(A)**, which is therefore the only binding acoustic specification (the values of the Octave bands in the table are indicative).

SPL = Sound pressure levels, with reference to 2×10^{-5} Pa.

The sound pressure levels are values calculated by applying the **ISO-3744 relation (Eurovent 8/1)** and refer to a distance of 1 meter away from the external surface of units operating in the open field with directivity factor 2 (Q=2) and the units operating in nominal conditions in the cooling mode.

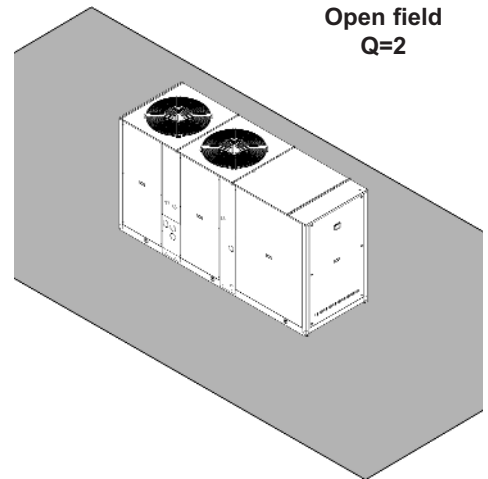

AB Standard unit

Mod.	SWL (dB)								Total		SPL (dBA)		
	Octave bands (Hz)										1m	5m	10m
	63	125	250	500	1000	2000	4000	8000	dB	dB(A)(E)			
50	89.4	87.0	84.8	80.3	77.4	73.8	65.3	56.0	93	83	65	56	51
60	89.4	87.0	84.8	80.3	77.4	73.8	65.3	56.0	93	83	65	56	51
70	91.2	88.9	86.4	82.3	78.0	71.6	64.0	55.6	94	84	66	57	52
80	91.2	88.9	86.4	82.3	78.0	71.6	64.0	55.6	94	84	66	57	52
90	92.2	89.9	87.4	83.3	79.0	72.6	65.0	56.6	95	85	67	58	53
100	92.2	89.9	87.4	83.3	79.0	72.6	65.0	56.6	95	85	67	58	53
115	92.2	89.9	87.4	83.3	79.0	72.6	65.0	56.6	95	85	66	58	53
130	92.4	90.0	87.8	83.3	80.4	76.8	68.3	59.0	96	86	67	59	54
145	94.2	91.9	89.4	85.3	81.0	74.6	67.0	58.6	97	87	68	60	55
160	94.2	91.9	89.4	85.3	81.0	74.6	67.0	58.6	97	87	68	60	55
180	92.4	90.1	88.6	86.0	83.2	77.8	71.2	62.8	96	88	69	61	56
200	92.4	90.1	88.6	86.0	83.2	77.8	71.2	62.8	96	88	69	61	56

AS Low noise unit

Mod.	SWL (dB)								Total		SPL (dBA)		
	Octave bands (Hz)										1m	5m	10m
	63	125	250	500	1000	2000	4000	8000	dB	dB(A)(E)			
50	83.4	86.3	82.6	77.8	74.3	67.8	59.2	50.3	90	80	62	53	48
60	83.4	86.3	82.6	77.8	74.3	67.8	59.2	50.3	90	80	62	53	48
70	84.4	87.3	83.6	78.8	75.3	68.8	60.2	51.3	91	81	63	54	49
80	84.4	87.3	83.6	78.8	75.3	68.8	60.2	51.3	91	81	63	54	49
90	85.4	88.3	84.6	79.8	76.3	69.8	61.2	52.3	92	82	64	55	50
100	85.4	88.3	84.6	79.8	76.3	69.8	61.2	52.3	92	82	64	55	50
115	85.4	88.3	84.6	79.8	76.3	69.8	61.2	52.3	92	82	63	55	50
130	89.4	87.0	84.8	80.3	77.4	73.8	65.3	56.0	93	83	64	56	51
145	91.2	88.9	86.4	82.3	78.0	71.6	64.0	55.6	94	84	65	57	52
160	91.2	88.9	86.4	82.3	78.0	71.6	64.0	55.6	94	84	65	57	52
180	92.2	89.9	87.4	83.3	79.0	72.6	65.0	56.6	95	85	66	58	53
200	92.2	89.9	87.4	83.3	79.0	72.6	65.0	56.6	95	85	66	58	53

AX Extra low noise unit

Mod.	SWL (dB)								Total		SPL (dBA)		
	Octave bands (Hz)										1m	5m	10m
	63	125	250	500	1000	2000	4000	8000	dB	dB(A)(E)			
50	89.0	81.0	80.0	76.0	72.0	67.0	62.0	52.0	90	78	60	51	46
60	89.0	81.0	80.0	76.0	72.0	67.0	62.0	52.0	90	78	60	51	46
70	90.0	82.0	81.0	77.0	73.5	67.0	64.0	52.0	91	79	61	52	47
80	90.0	82.0	81.0	77.0	73.5	67.0	64.0	52.0	91	79	61	52	47
90	83.4	86.3	82.6	77.8	74.3	67.8	59.2	50.3	90	80	62	53	48
100	83.4	86.3	82.6	77.8	74.3	67.8	59.2	50.3	90	80	62	53	48
115	83.4	86.3	82.6	77.8	74.3	67.8	59.2	50.3	90	80	61	53	48
130	84.4	87.3	83.6	78.8	75.3	68.8	60.2	51.3	91	81	62	54	49
145	85.4	88.3	84.6	79.8	76.3	69.8	61.2	52.3	92	82	63	55	50
160	85.4	88.3	84.6	79.8	76.3	69.8	61.2	52.3	92	82	63	55	50
180	89.4	87.0	84.8	80.3	77.4	73.8	65.3	56.0	93	83	64	56	51
200	89.4	87.0	84.8	80.3	77.4	73.8	65.3	56.0	93	83	64	56	51

(E): data declared according to **LCP EUROVENT** certification program. The values are for units without options and accessories.

OPERATING RANGE

Operating range

The graphs below give the operating ranges within which correct operation of the units is guaranteed. The use of the units in conditions differing from those indicated will void the warranty with which the product is supplied. In the following table, there are the thermal water head limit values of the unit.

Thermal Water Head		Limit value
Minimum	°C	3
Maximum	°C	8

Note: Make sure the water flow is within the minimum and maximum pressure drop as reported "water pressure drop plate heat exchanger".

COOLING MODE

Medium Temperature 0M5

High Temperature 0A5

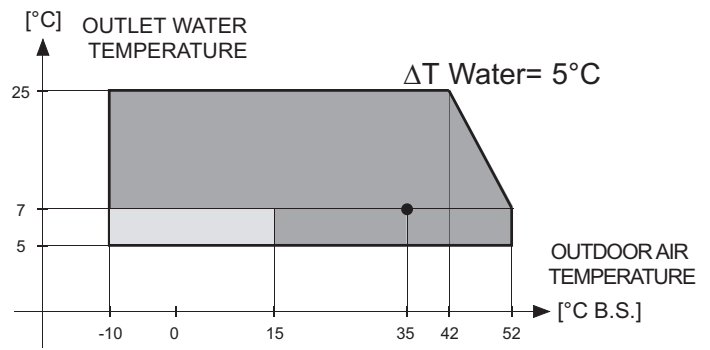
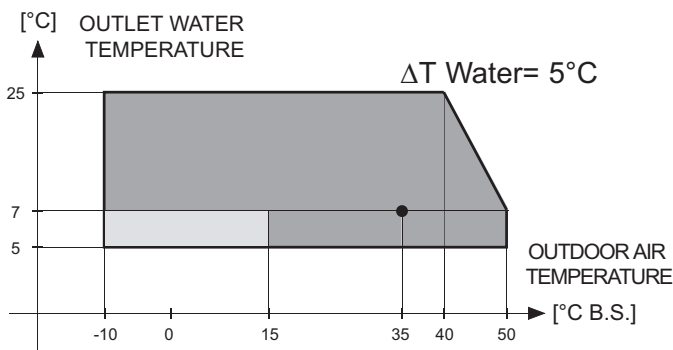

In these applications, it's advisable to use brine.

HEATING MODE

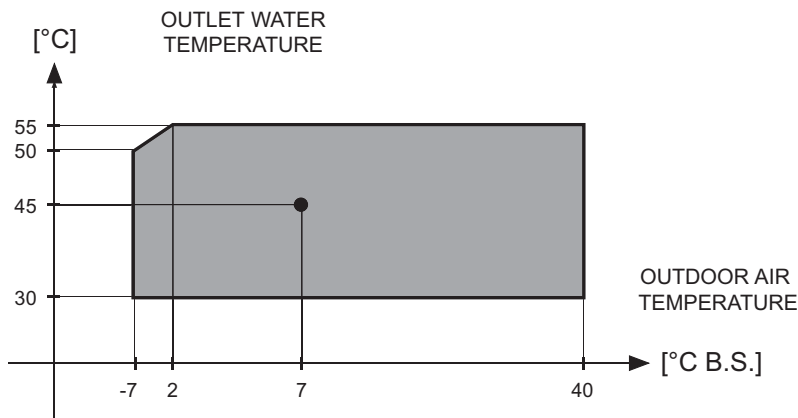

COOLING MODE Brine Unit (BR - BP)

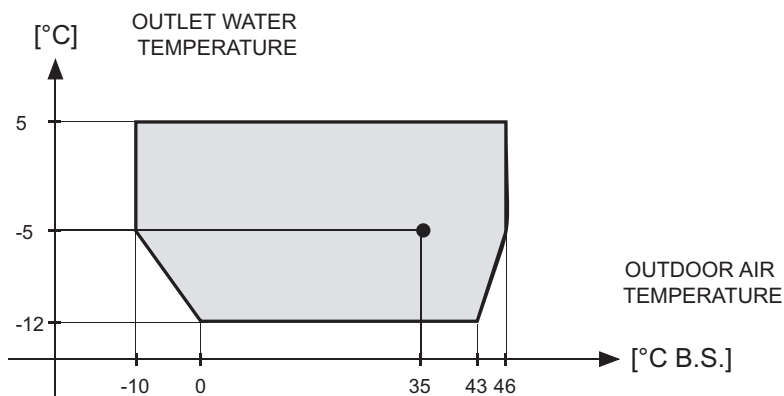

Use water glicol as specified in the paragraph "Specification data for Brine Unit BR - BP".

WATER PRESSURE DROP PLATE HEAT EXCHANGER

The graph below illustrates the water pressure drop values in **kPa** depending on the flow rate in **liters/second**. The operating range is delimited by the minimum and maximum values given in the next table.

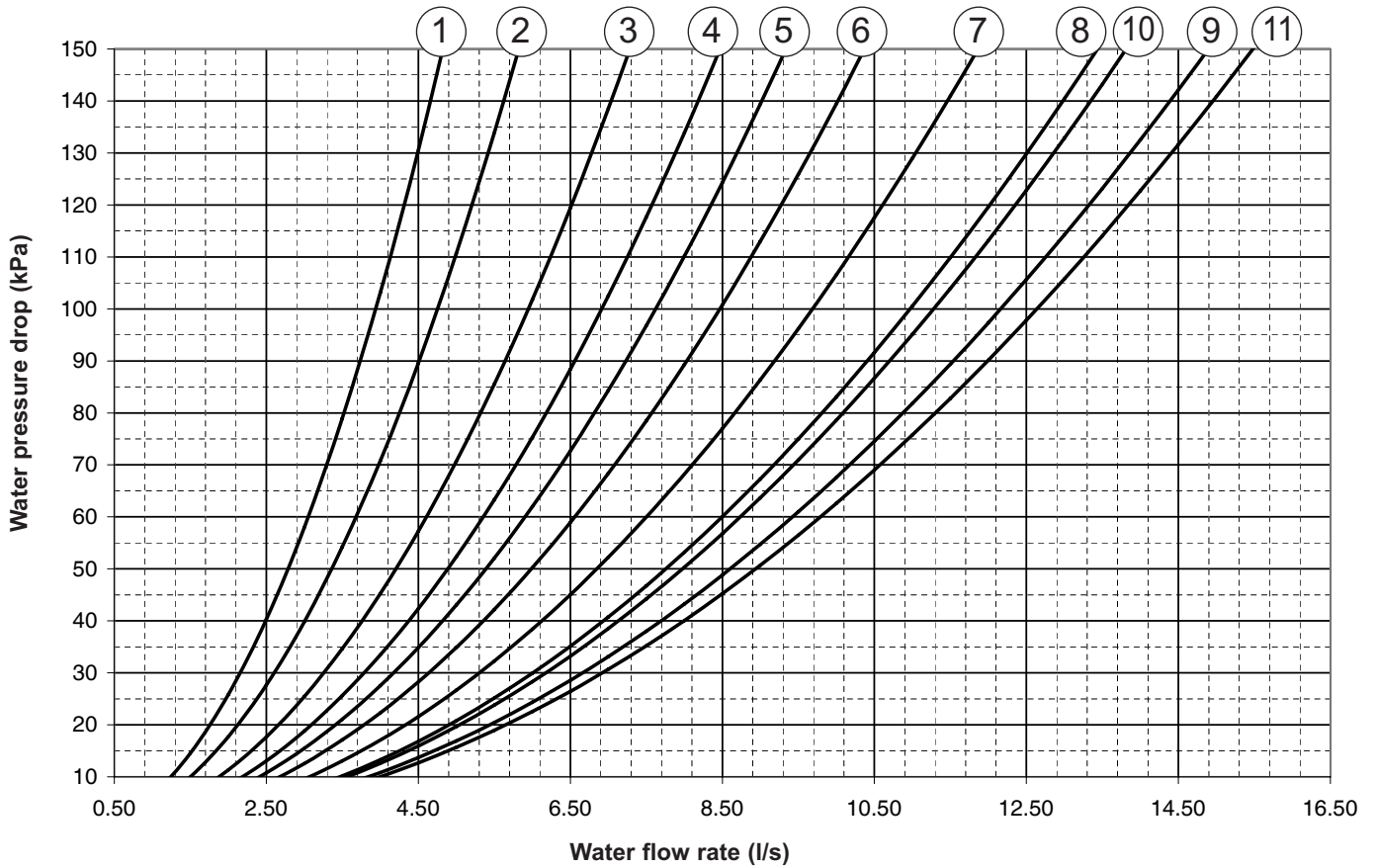

Operation range

Unit Size		50	60	70	80	90	100	115	130	145	160	180	200	UM	NOTES
Graph reference		1	2	3	4	5	6	7	8	9	10	11			Q =Water flow rate Δp =Water pressure drop
Lower limit value	Q	1.2	1.5	1.9	2.2	2.4	2.7	3.1	3.5	3.8	3.6	4.0	l/s		
	Δp	10											kPa		
Upper limit value	Q	4.8	5.8	7.3	8.5	9.3	10.4	11.9	13.4	14.9	13.8	15.5	l/s		
	Δp	150											kPa		
Max. operating pressure on wet side		600											kPa		

WATER PRESSURE DROP OF THE DESUPERHEATER VD

The graph below illustrates the water pressure drop values in **kPa** depending on the flow rate in **liters/second**, for the Special Versions with Desuperheater (VD) in both the units that operate in the Cooling mode only (IR) and in Heat Pump units (IP). The operating range is delimited by the minimum and maximum values given in the next table.

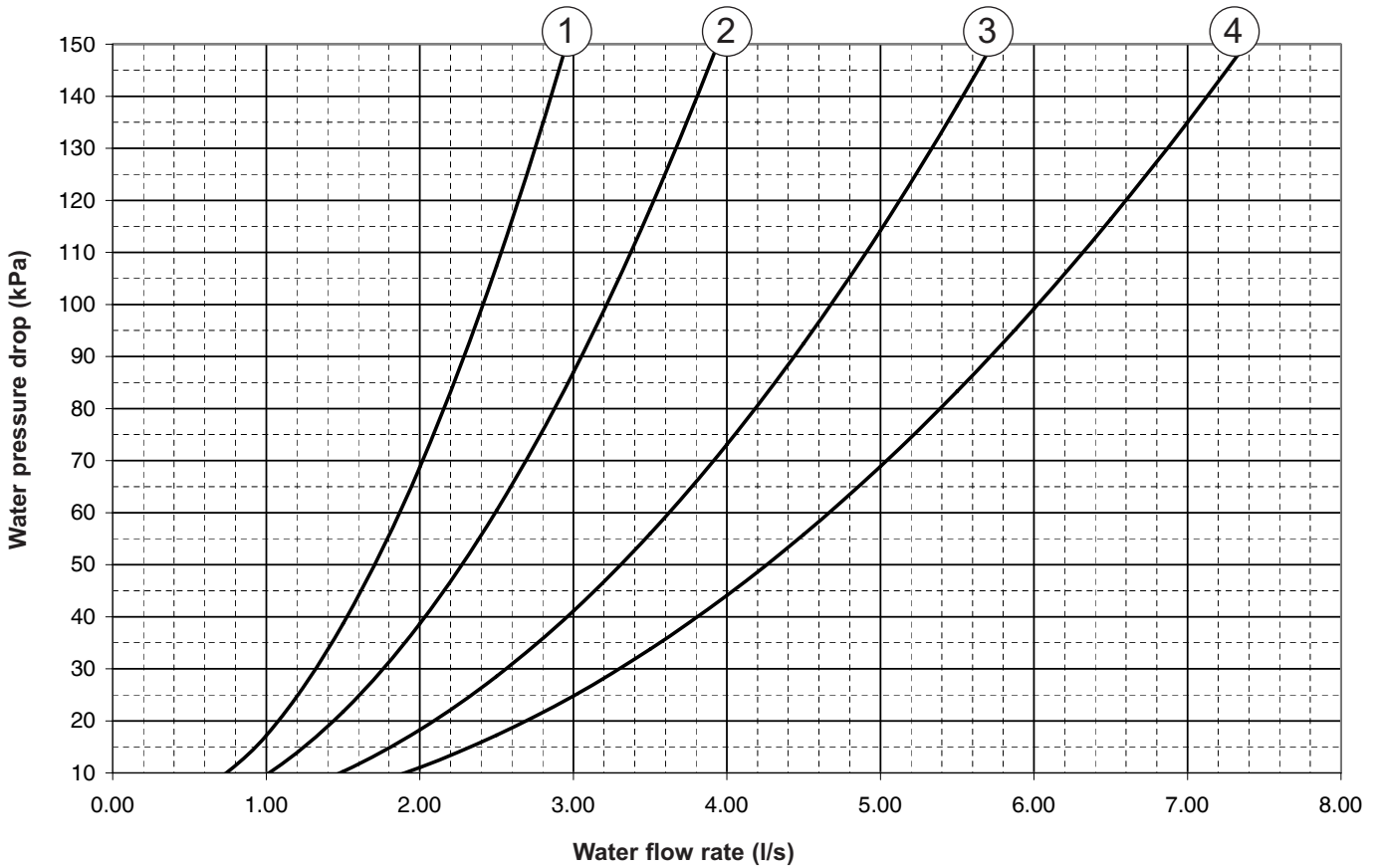

Operation range

Unit Size		50	60	70	80	90	100	115	130	145	160	180	200	UM	NOTES
Graph reference		1				2		3			4				Q =Water flow rate Δp =Water pressure drop
Lower limit value	Q	0.8				1.0		1.5			1.9		l/s		
	Δp	10											kPa		
Upper limit value	Q	3.0				3.9		5.7			7.4		l/s		
	Δp	150											kPa		
Max. operating pressure on wet side		600											kPa		

WATER PRESSURE DROP TOTAL HEAT RECOVERY VR

The graph below illustrates the water pressure drop values in **kPa** depending on the flow rate in **liters/second**, for the Special Versions with Total heat recovery (VD) in both the units that operate in the Cooling mode only (IR). The operating range is delimited by the minimum and maximum values given in the next table.

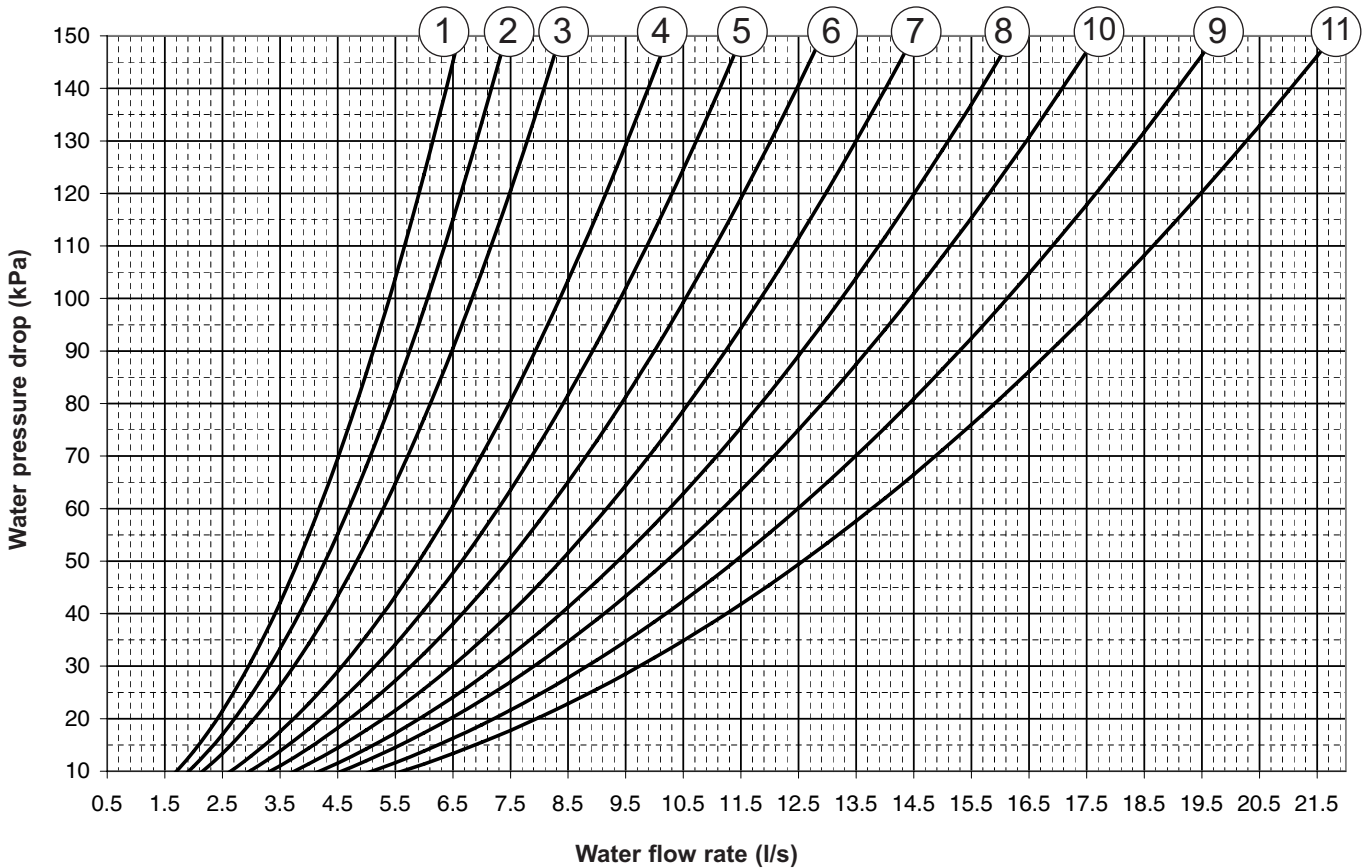

Operation range

Unit Size		50	60	70	80	90	100	115	130	145	160	180	200	UM	NOTES
Graph reference		1	2	3	4	5	6	7	8	9	10	11			Q =Water flow rate Δp =Water pressure drop
Lower limit value	Q	1.71	1.71	1.92	2.16	2.64	2.98	3.33	3.74	4.19	4.56	5.10	5.62	l/s	
	Δp	10											kPa		
Water flow recovery (1)	Q	3.37	3.72	4.37	5.02	5.73	6.45	7.07	8.03	9.08	10	11.4	12.7	l/s	
Pressure drop recovery (1)	Δp	39	47	52	54	47	47	45	46	47	48	50	51	kPa	
Upper limit value	Q	3.37	3.72	4.37	5.02	5.73	6.45	7.07	8.03	9.08	10	11.4	12.7	l/s	
	Δp	150											kPa		
Max. operating pressure on wet side		600											kPa		

(1): water temperature: evaporator inlet 12°C - evaporator outlet 7°C
 water temperature: recovery inlet 40°C - recovery outlet 45°C

WORKING HEAD OF THE HYDRONIC KIT MP AM STD, MP SS STD AND MPM AM STD

The following graph gives the head values (kPa) depending on the water flow rate (liters/second). The operating range is delimited by the minimum and maximum values given in the next table.

Working head is the one on the wet module outlet minus all the water pressure drop of the unit.

For hydronic kit with **inverter pump (MPM)** the graphic is at the maximum pump speed, for lower speed values curve decreases according to the following formulas:

$$Q_2 = Q_1 * \frac{n_2}{n_1} \quad n: \text{ pump speed [Hz]}$$

$$H_2 = H_1 * \frac{n_2^2}{n_1^2} \quad Q: \text{ water flow [l/s]} \quad H: \text{ working head [kPa]}$$

$$P_2 = P_1 * \frac{n_2^3}{n_1^3} \quad P: \text{ power input [kW]}$$

$$n_1 = 100\% \\ 30\% \leq n_2 \leq 100\%$$

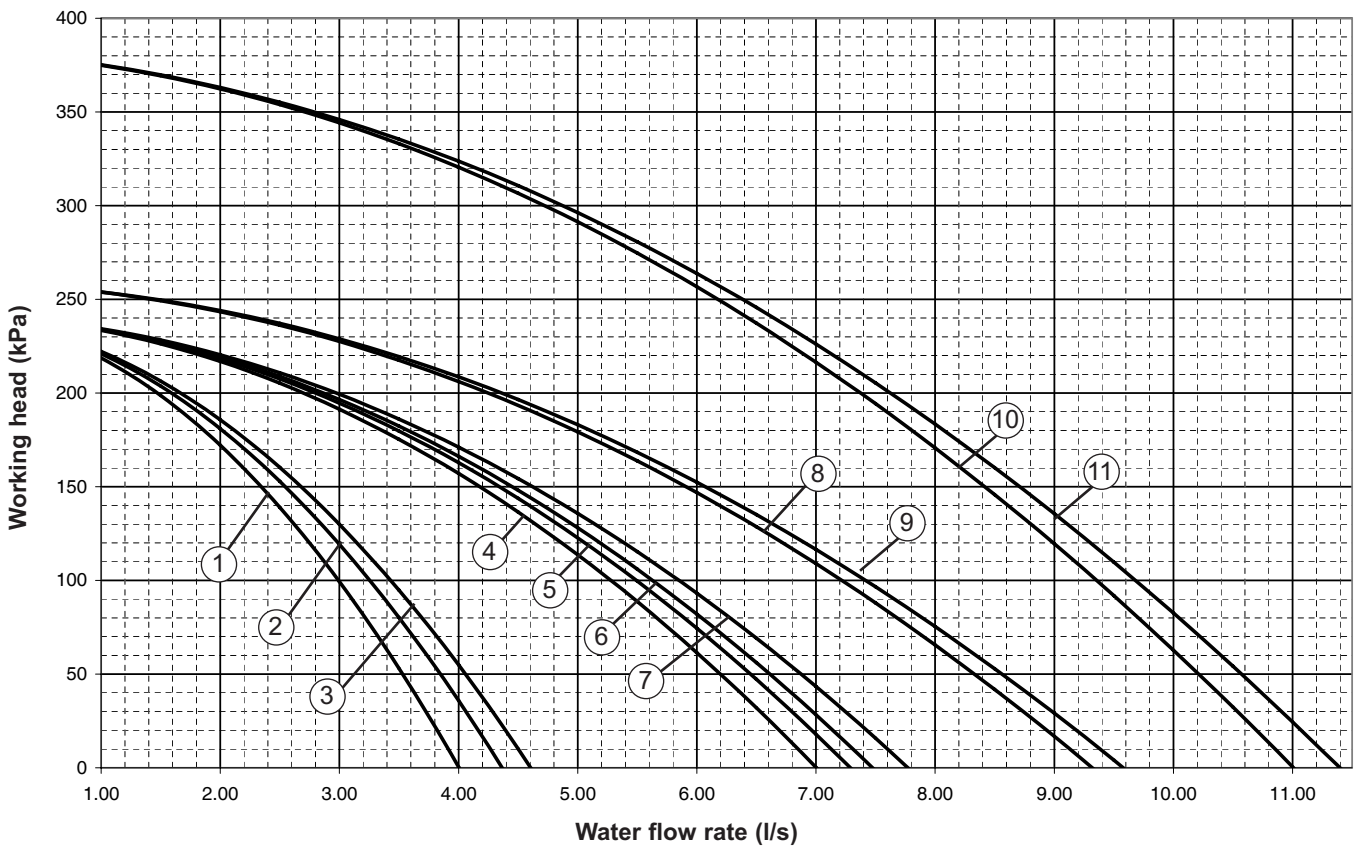

Operation range

Unit Size	50	60	70	80	90	100	115	130	145	160	180	200	UM	NOTES
Graph reference	1		2	3	4	5	6	7	8	9	10	11		Q=Water flow rate
Lower limit value	1.25		1.50	1.88	2.19	2.41	2.68	3.06	3.47	3.85	3.57	4.00	l/s	
Upper limit value	4.00		4.36	4.61	6.71	7.00	7.29	7.48	9.32	9.58	11.00	11.40	l/s	
Max. operating pressure on wet side	600												kPa	

HIGH WORKING HEAD OF THE HYDRONIC KIT MP AM HP1, MP SS HP1 AND MPM AM HP1

The following graph gives the head values (**kPa**) depending on the water flow rate (**liters/second**). The operating range is delimited by the minimum and maximum values given in the next table.

Working head is the one on the wet module outlet minus all the water pressure drop of the unit.

For hydronic kit with **inverter pump (MPM)** the graphic is at the maximum pump speed, for lower speed values curve decreases according to the following formulas:

$$Q_2 = Q_1 * \frac{n_2}{n_1} \quad n: \text{pump speed [Hz]}$$

$$H_2 = H_1 * \frac{n_2^2}{n_1^2} \quad Q: \text{water flow [l/s]} \quad H: \text{working head [kPa]}$$

$$P_2 = P_1 * \frac{n_2^3}{n_1^3} \quad P: \text{power input [kW]}$$

$$n_1 = 100\% \\ 30\% \leq n_2 \leq 100\%$$

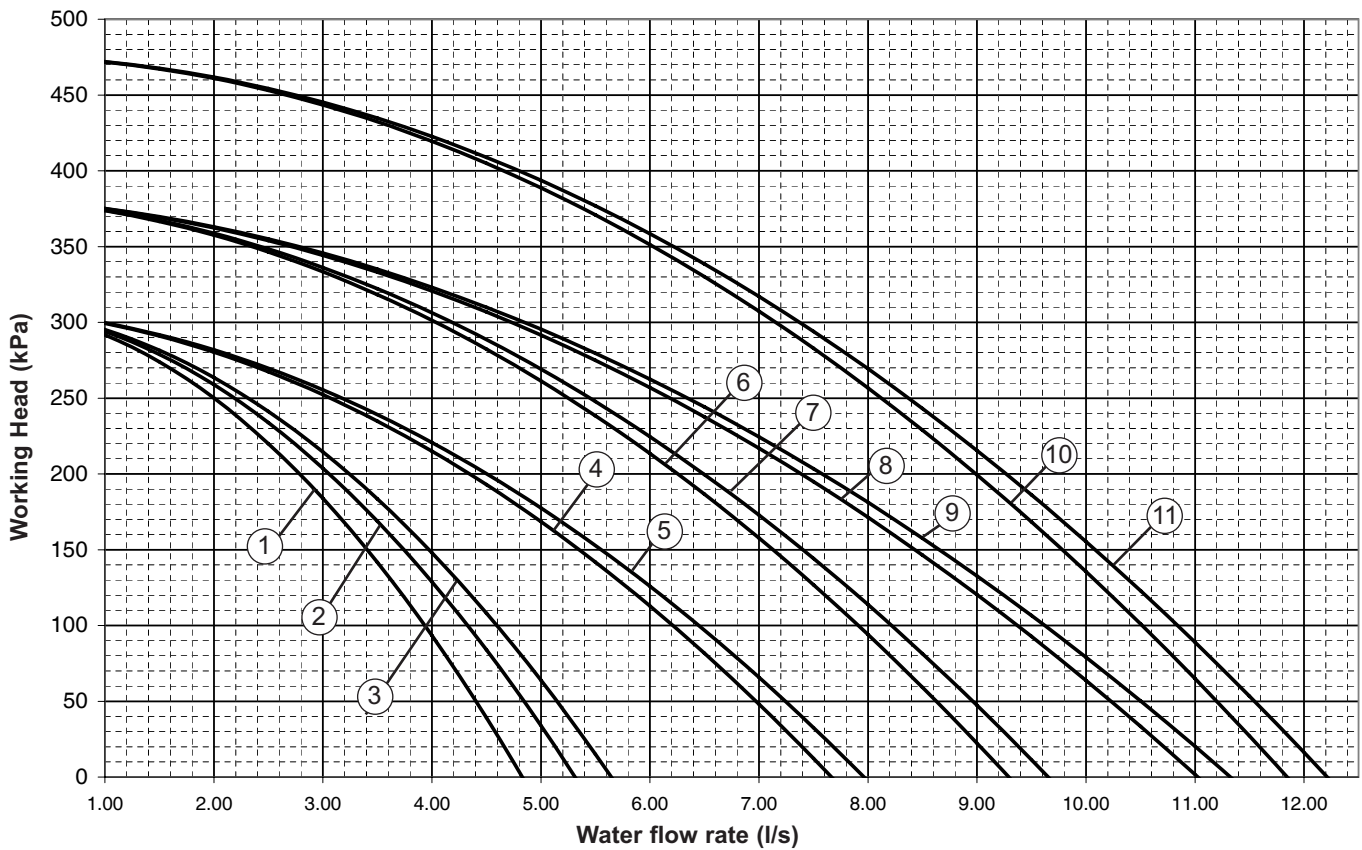

Operation range

Unit Size	50	60	70	80	90	100	115	130	145	160	180	200	UM	NOTES
Graph reference	1		2	3	4	5	6	7	8	9	10	11		Q=Water flow rate
Lower limit value	1.25		1.50	1.88	2.19	2.41	2.68	3.06	3.47	3.85	3.57	4.00	l/s	
Upper limit value	4.82		5.31	5.65	7.67	7.96	9.29	9.65	11.03	11.32	11.85	12.21	l/s	
Max. operating pressure on wet side	600												kPa	

MAXIMUM VOLUME OF WATER

Maximum volume of water in the system with wet module

Before filling the water system, it is advisable to consider the type of installation in question, i.e. check the difference in level between the wet module and user. The following table gives the maximum water content of the water supply system in liters, depending on the capacity of the standard surge chamber supplied and the pressure at which it should be charged. The surge chamber setting must be regulated to suit the maximum positive difference in level of the user.

Maximum setting value 600 kPa.

With a positive H of more than 12.25 meters, calculate the surge chamber's service charge value in kPa using the formula below:

$$\text{Surge chamber service charge} = [H/10.2 + 0.3] \times 100 = [\text{kPa}]$$

NOTE: In case A, make sure that the user's lowest point is able to withstand the global pressure.

Tab.1

Model		50-60-70-80	90-100-110-115-130-145-160-180-200			
Surge chamber volume (liters)		12	24			
Thermal expansion of water (10-40°C)		0.0074				
Thermal expansion of water (10-60°C)		0.0167				
H (meters)		Surge chamber pressure (kPa)	Maximum total volume of water supply system (liters)			
			IR	IP	IR	IP
Case A	H < 0	150 (standard)	1043	461	2085	921
	0 < H < 12.25	150 (standard)	1043	461	2085	921
Case B	15	177	980	435	1960	870
	20	226	866	384	1732	768
	25	275	753	334	1505	667
	30	324	640	283	1279	566

NOTE: If the unit operates with brine, calculate the real volume of the system by taking into account the corrective factors for the volume of the system given in the table below.

Corrective factors per total maximum volume of the system with brine

% of brine	0%	10%	20%	30%	40%
Cooling Mode	1.000	0.738	0.693	0.652	0.615
Heating Mode	1.000	0.855	0.811	0.769	0.731

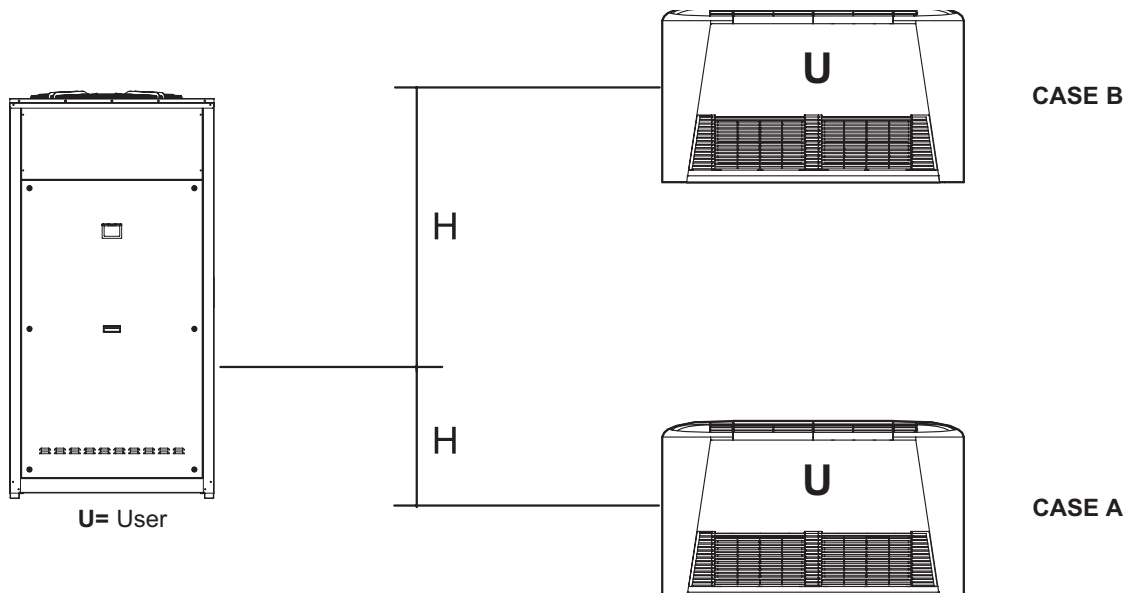

DIMENSIONAL DATA

Overall dimensions

Mod. 50-60-70-80

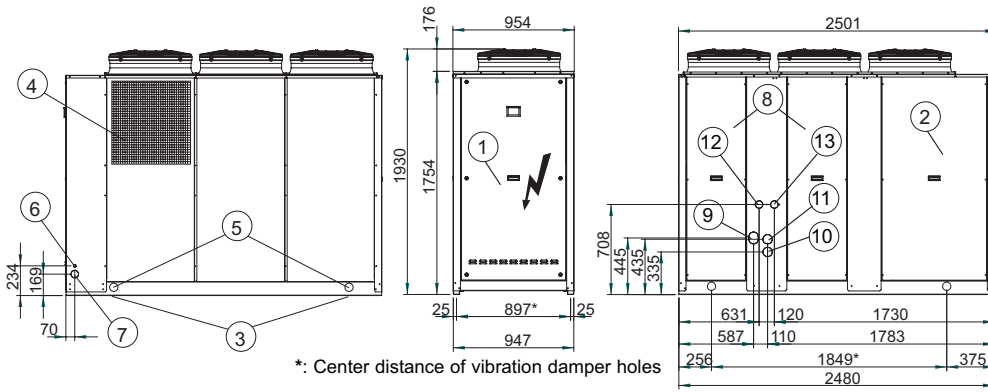

Mod. 90-100

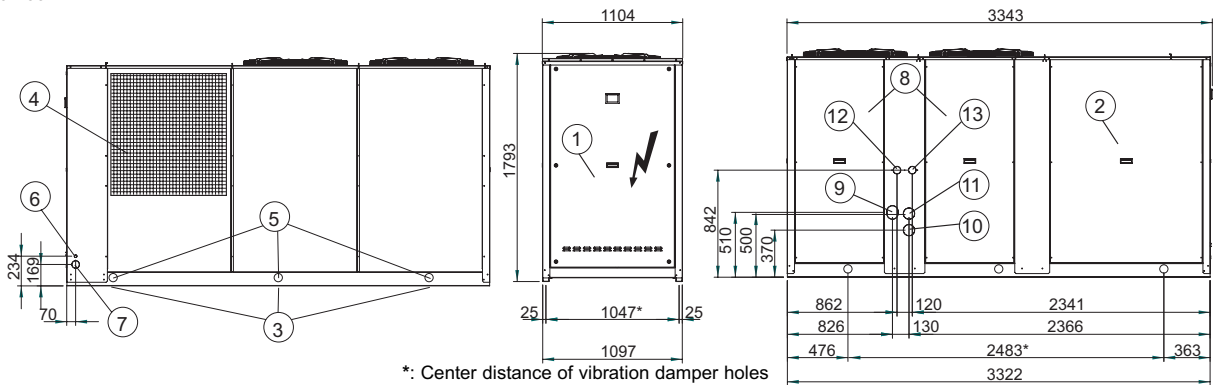

Mod. 115-130-145-160

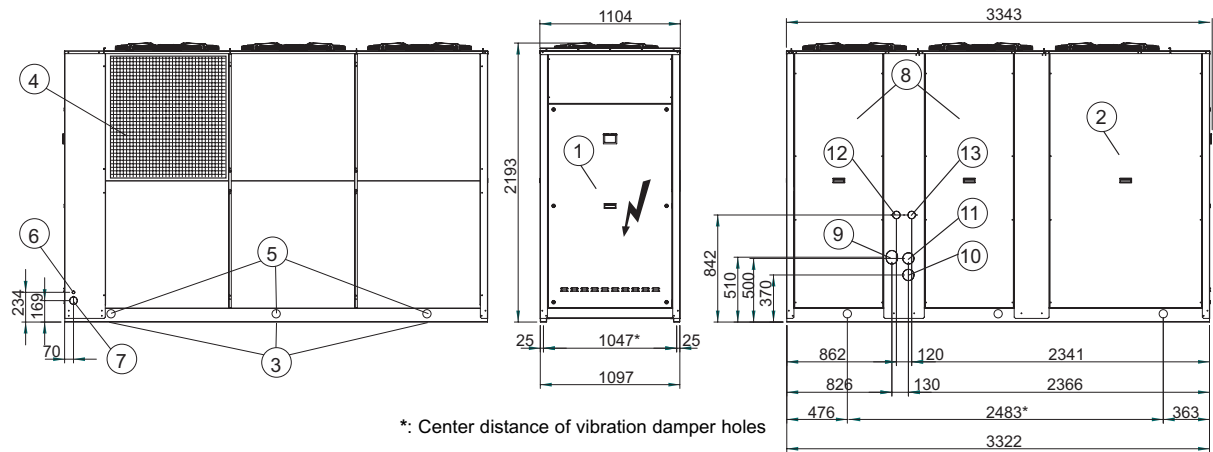

Mod. 180-200

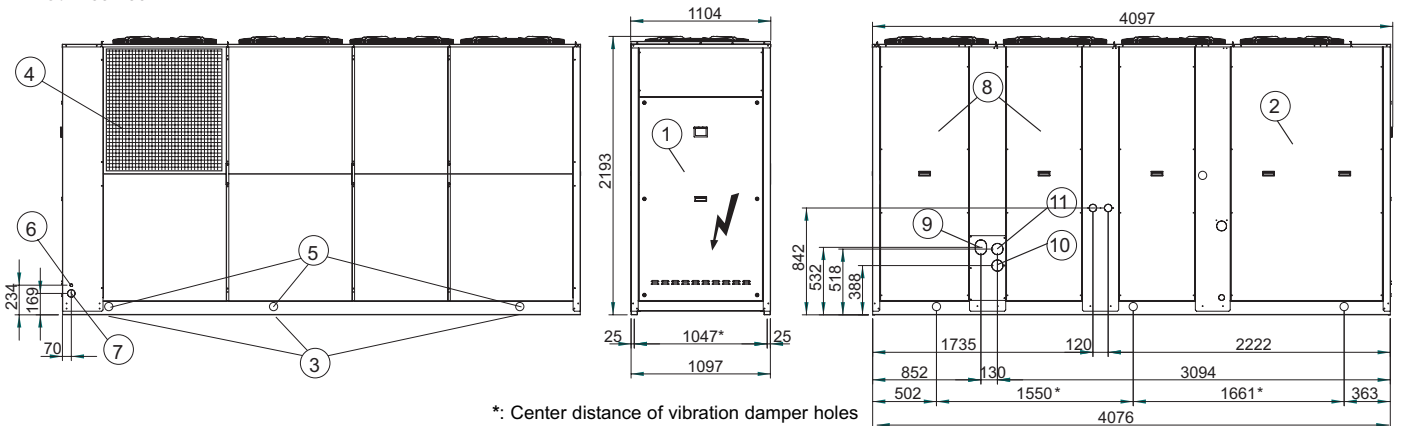

DIMENSIONAL DATA

Description of the components

- | | |
|----------------------------------------------------------------------------------------------------------------------------------------------------------------------------------------------------------------------------------------------------------------------------------------------------------------------------------------------------------------------------------------------------------------------------------------------------------------------------------------------------------------------------------------------------------------------------------------|--------------------------------------------------------------------------------------------------------------------------------------------------------------------------------------------------------------------------------------------------------------------------------------------------------------------------------------------|
| <ul style="list-style-type: none"> 1 - Access panel to electric panel's power section 2 - Access panel to compressor compartment 3 - Vibration damper fixing holes (4 pcs) 4 - Coil protection grilles (accessory) 5 - \varnothing 65 mm lifting holes 6 - \varnothing 22 mm input hole for accessory cables 7 - \varnothing 60 mm hole for electric power supply input 8 - Access panel to pump compartment 9 - Water inlet for MP AM STD and MP SS STD | <ul style="list-style-type: none"> 10 - Water inlet for KT and MP PS STD 11 - Water outlet 12 - Water inlet for Desuperheater (only VD-VR version) 13 - Water outlet for Desuperheater (only VD-VR version) <p>Note (1): Victaulic connections Kit do not allow external connections.</p> |
|----------------------------------------------------------------------------------------------------------------------------------------------------------------------------------------------------------------------------------------------------------------------------------------------------------------------------------------------------------------------------------------------------------------------------------------------------------------------------------------------------------------------------------------------------------------------------------------|--------------------------------------------------------------------------------------------------------------------------------------------------------------------------------------------------------------------------------------------------------------------------------------------------------------------------------------------|

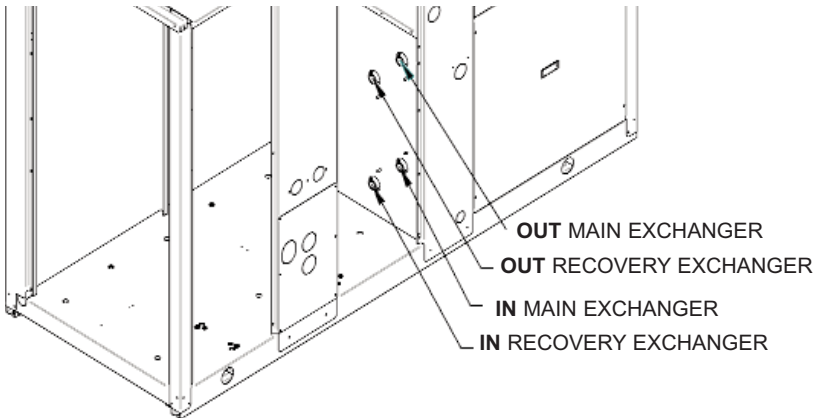

		Rif.	50÷80	90÷200
VICTAULIC CONNECTIONS KIT	IN (1)		2" M	2 ½" M
	OUT (1)			
PIPES KIT COMPLETE	IN 10		1 ½" VIC	2" VIC
	OUT 11			
PIPES KIT WITH TANK	IN 10		1 ½" VIC	2" VIC
	OUT 11			
M1P M2P AM STD	IN 9		2" VIC	2 ½" VIC
	OUT 11			
M1P M2P AM HP1	IN 9		2" VIC	2 ½" VIC
	OUT 11			
M1P M2P SS STD	IN 9		2" VIC	2 ½" VIC
	OUT 11			
M1P M2P SS HP1	IN 9		2" VIC	2 ½" VIC
	OUT 11			
M1P M2P PS STD	IN 10		2" VIC	2 ½" VIC
	OUT 11			
VD	IN 12		1 ½" VIC	1 ¼" VIC
	OUT 13			
VR	IN 12		2" VIC	2 ½" VIC
	OUT 13			

Minimum space required for operation

To correctly install the unit, comply with the measurements for the free area that must be left around the machine, as shown in the figure.

This will ensure good air circulation, allow the unit to operate correctly and facilitate future maintenance work.

The distances must be doubled if the unit is to be installed in a pit.

NOTE. Allow for an uncluttered area of not less than 2.5 meters above the unit.

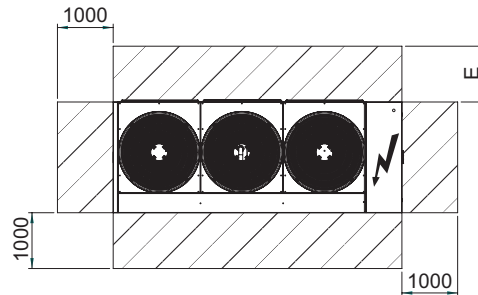

Modello	50-80	90-100	115-200
E [mm]	1600		2000

Position of condensate drain

The condensate tray (if present) must have a suitable drain trap to prevent spilling of water during operation.

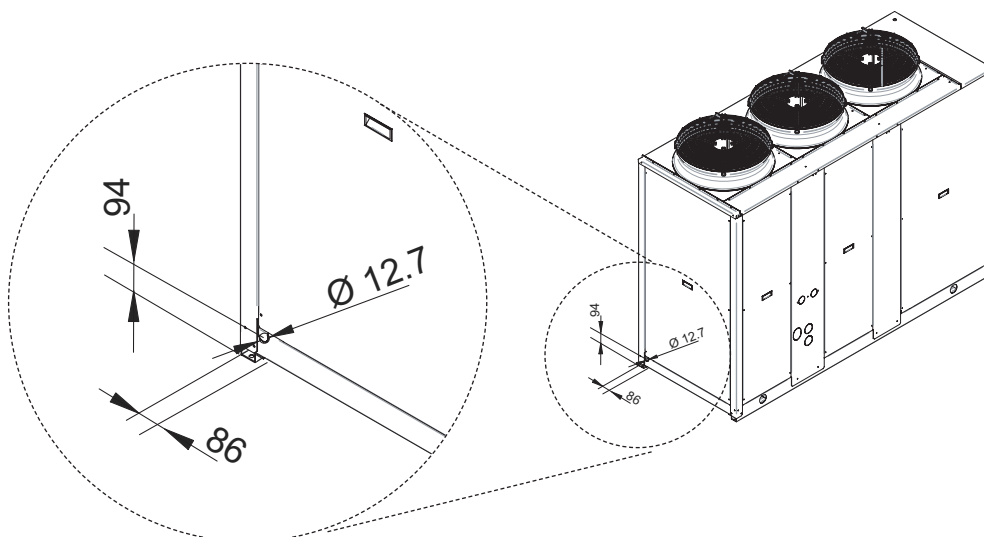

WEIGHT DURING OPERATION AND TRANSPORT

UNIT WITHOUT WATER STORAGE TANK

Unit WITHOUT Hydronic Kit

Weight during transport					Weight during operation				
IR Version			IP Version		IR Version			IP Version	
Acoustic version	AB-AS	AX	AB-AS	AX	Acoustic version	AB-AS	AX	AB-AS	AX
Mod.	Weight [Kg]		Weight [Kg]		Mod.	Weight [Kg]		Weight [Kg]	
50	591	614	623	646	50	595	617	626	650
60	592	614	624	646	60	596	617	627	651
70	630	646	663	679	70	634	651	667	683
80	656	663	688	695	80	661	668	693	700
90	893	913	932	952	90	900	921	938	960
100	973	993	1012	1032	100	981	1001	1021	1040
115	1083	1112	1126	1155	115	1093	1121	1137	1165
130	1110	1138	1153	1182	130	1121	1150	1164	1192
145	1163	1191	1210	1238	145	1177	1205	1223	1251
160	1211	1223	1260	1273	160	1225	1237	1275	1288
180	1356	1389	1407	1440	180	1367	1381	1418	1451
200	1400	1414	1451	1466	200	1413	1427	1464	1479

Unit WITH Hydronic Kit

Weight during transport					Weight during operation				
IR Version			IP Version		IR Version			IP Version	
Acoustic version	AB-AS	AX	AB-AS	AX	Acoustic version	AB-AS	AX	AB-AS	AX
Mod.	Weight [Kg]		Weight [Kg]		Mod.	Weight [Kg]		Weight [Kg]	
50	626	650	738	761	50	728	749	759	782
60	627	651	739	761	60	728	750	760	782
70	667	683	778	794	70	766	783	800	815
80	693	700	803	811	80	793	801	825	833
90	938	960	1076	1096	90	1066	1087	1105	1125
100	1021	1040	1156	1176	100	1147	1167	1185	1206
115	1137	1165	1282	1311	115	1272	1301	1315	1343
130	1164	1192	1309	1338	130	1299	1328	1343	1372
145	1223	1251	1366	1394	145	1356	1385	1402	1430
160	1275	1288	1416	1430	160	1405	1419	1454	1469
180	1418	1451	1606	1639	180	1597	1629	1646	1680
200	1464	1479	1650	1667	200	1642	1658	1692	1709

UNIT WITH WATER STORAGE TANK

Unit WITHOUT Hydronic Kit

Weight during transport					Weight during operation				
IR Version			IP Version		IR Version			IP Version	
Acoustic version	AB-AS	AX	AB-AS	AX	Acoustic version	AB-AS	AX	AB-AS	AX
Mod.	Weight [Kg]		Weight [Kg]		Mod.	Weight [Kg]		Weight [Kg]	
50	665	688	697	720	50	877	899	909	931
60	666	688	698	720	60	877	900	910	932
70	704	720	737	753	70	917	932	951	966
80	729	736	761	769	80	943	952	976	986
90	997	1018	1036	1056	90	1378	1398	1418	1437
100	1077	1098	1116	1136	100	1459	1479	1498	1519
115	1187	1216	1231	1259	115	1571	1599	1614	1642
130	1214	1243	1258	1286	130	1598	1628	1642	1671
145	1267	1296	1314	1343	145	1655	1683	1701	1729
160	1315	1328	1364	1378	160	1704	1721	1753	1771
180	1497	1530	1548	1581	180	1971	2004	2021	2056
200	1541	1556	1592	1608	200	2016	2036	2067	2088

Unit WITH Hydronic Kit

Weight during transport					Weight during operation				
IR Version			IP Version		IR Version			IP Version	
Acoustic version	AB-AS	AX	AB-AS	AX	Acoustic version	AB-AS	AX	AB-AS	AX
Mod.	Weight [Kg]		Weight [Kg]		Mod.	Weight [Kg]		Weight [Kg]	
50	770	793	802	825	50	998	1021	1030	1052
60	771	794	803	826	60	998	1022	1030	1053
70	810	825	843	858	70	1038	1055	1072	1088
80	835	843	867	876	80	1064	1075	1096	1107
90	1127	1147	1165	1186	90	1528	1548	1566	1587
100	1207	1227	1245	1266	100	1608	1629	1647	1668
115	1329	1357	1372	1401	115	1734	1762	1776	1805
130	1355	1384	1399	1427	130	1761	1791	1805	1833
145	1408	1437	1456	1484	145	1817	1846	1863	1891
160	1457	1472	1506	1521	160	1866	1885	1916	1935
180	1675	1708	1726	1759	180	2176	2210	2227	2260
200	1719	1736	1770	1788	200	2222	2244	2273	2296

The manufacturer declines all responsibility for any inaccuracies in this manual due to printing or typing errors.
The reserves the right to modify the products contents in this catalogue without previous notice.

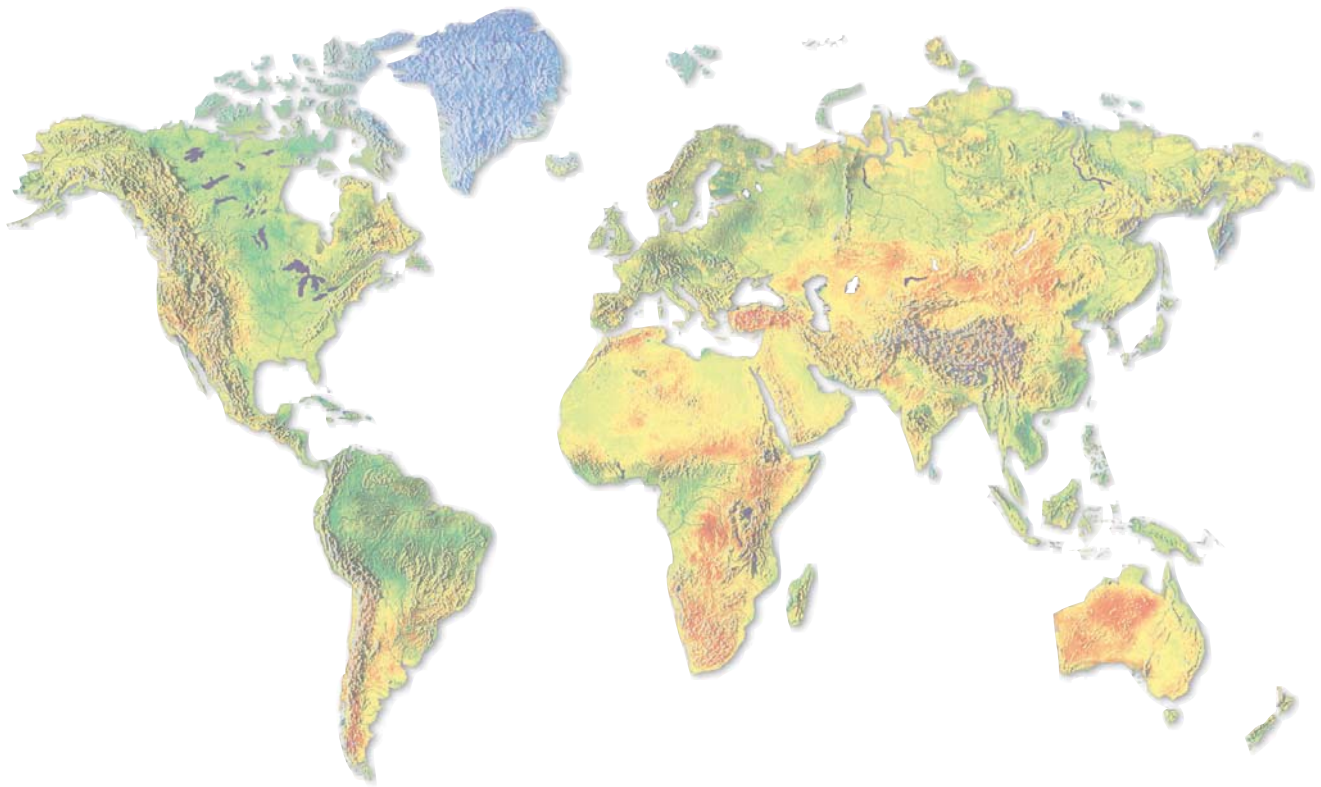

FERROLI *around the World*

ITALY www.ferroli.it

SPAIN www.ferroli.es

FRANCE www.ferroli.fr

GERMANY www.ferroli.de

UNITED KINGDOM www.dpac.co.uk

NETHERLANDS www.ferroli.nl

CROATIA www.ferroli.hr

ROMANIA www.ferroli.ro

TURKEY www.ferroli.com.tr

HUNGARY www.ferroli.hu

POLAND www.ferroli.com.pl

UKRAINE www.ferroli.ua

RUSSIA www.ferroli-ac.ru

BELARUS www.ferroli.klimatoff.com

CHINA www.ferroli.com.cn

WARNING FOR TRADERS:

As part of its efforts to constantly improve its range of products, with the aim of increasing the level of Customer satisfaction, the Company stresses that the appearance, dimensions, technical data and accessories may be subject to variation. Consequently, ensure that the Customer is provided with updated documents. The products described in this document are covered by warranty if purchased and installed in Italy.

